

KLAY-INSTRUMENTS

INSTRUCTION MANUAL

"Intelligent" Pressure and level transmitters

SERIES 9000 and 9000-SAN

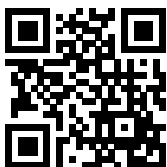

Read the recommendations and warnings in this manual before the instrument is installed. For personal safety, optimal use and maintenance of the Series 9000, these instructions should be studied carefully.

Manufactured by:

 **KLAY-INSTRUMENTS B.V.**

www.klay.nl

Nijverheidsweg 5
P.O. Box 13
Tel: +31-521-591550
Fax: +31-521-592046

7991 CZ DWINGELOO
7990 AA DWINGELOO
The Netherlands
E-mail: info@klay.nl

TABLE OF CONTENTS

1.	INTRODUCTION.....	3
1.1	DESCRIPTION SERIES 9000-SAN	3
1.2	DESCRIPTION SERIES 9000.....	3
1.3	BAROMETRIC REFERENCE	3
2.	DIMENSIONAL DRAWINGS	4
3.	INSTALLING THE TRANSMITTER	5
3.1	INSTALLING WELD-ON NIPPLE	5
3.2	INSTALLING TRANSMITTER SERIES 9000-SAN (Code W)	5
3.3	INSTALLING TRANSMITTER SERIES 9000 (Code W33).....	5
3.4	MOUNTING POSITION.....	5
3.5	MOUNTING POSITION EFFECT	6
3.6	CALIBRATION	6
3.7	CONNECTION TERMINAL.....	6
3.8	WIRING.....	6
4.	REMAINING	7
4.2	CE/EMC-RULES.....	7
4.3	TRACEABILITY / YEAR OF MANUFACTURING	7
5.	DISPLAY AND PUSH BUTTONS	7
5.2	SUMMARY PROGRAMMING POINTS	8
6.	EXPLANATION PROGRAMMING POINTS	8
6.1	ZERO ADJUSTMENT (ZERO)	8
6.2	SPAN ADJUSTMENT (SPAN).....	8
6.3	CANCEL MOUNTING POSITION EFFECT	9
6.4	DISPLAY SETTING OF UNITS.....	9
6.5	OUTPUT SELECTION 4-20 mA or 20-4 mA.....	9
6.6	DAMPING ADJUSTMENT	10
6.7	TEMPERATURE UNITS	10
6.8	DEVICE SETUP	10
6.9	READOUT.....	10
6.10	BURST MODE (HART®)	11
7.	PROGRAMMING THE SERIES 9000	12
7.1	PROGRAMMING WITH HAND HELD TERMINAL	12
9.	SPECIFICATIONS	13
10.	PRECAUTIONS AND WARNINGS	14

1. INTRODUCTION

The SERIES 9000 and 9000-SAN are solid-state pressure- and level transmitters based upon a piezoresistive silicon sensor, with a very high burst pressure. The sensor element is mounted in a stainless steel foot. Inside the foot also a temperature sensor is mounted to ensure the process temperature. This temperature sensor is used to create an active temperature compensation. A strong stainless steel "flush" diaphragm protects the sensor from the process medium. A very small amount of special oil fills the chamber surrounding the sensor and transfers pressure from the flush mounted diaphragm to the sensor.

Pressure on the sensor element creates a very small deflection of the silicon substrate and bridge network. The resulting strain in the silicon resistors causes a change in the bridge resistance that is proportional to the pressure applied. The transmitter electronics detects this change in bridge resistance and converts it into a measuring value. The amplifier system is based on a single Integrated Circuit, which ensures a perfect linearity in the output, all within an accuracy of 0.2 %. Due to the **Klay flush diaphragm technology** the long term stability is perfect.

1.1 DESCRIPTION SERIES 9000-SAN

The SERIES 9000-SAN are specially designed with a flush mounted diaphragm so they fully meet the needs of the food, pharma and chemical industries. Standard the wetted parts are made of SS 316 L, other materials are available, like Hastelloy C. Various process connections can be delivered, such as Tri-Clamp (1,5", 2" and 3"), SMS (1,5" and 2"), dairy milk couplings (DN 25, 40 and 50), flanges (DIN and ANSI) and sanitary weld-on nipples (ø 48, 62 and 85 mm.)

1.2 DESCRIPTION SERIES 9000

The SERIES 9000 are specially designed for the pulp- and paper or similar industries, where clogging is a problem. The very compact construction of the SERIES 9000 permits flush installation with the tank- or pipe wall. Standard the wetted parts are made of SS 316, a lot of other materials like Hastelloy C and Gold plated are available as an option.

All transmitters are **fully temperature compensated**, which means that various process temperatures have nearly no effect on the accuracy of the output signal. When a failure occurs, the transmitter is repairable. However, for optimum accuracy the transmitter has to be send back to the factory.

1.3 BAROMETRIC REFERENCE

The SERIES 9000 (SAN) is in basic a so-called "relative transmitter" which means that barometric changes will not affect the zero. The venting is placed in the cover of the electronics housing next to the cable entry and is the filter for the barometric reference to atmospheric pressure. The venting must be kept clean.

2. DIMENSIONAL DRAWINGS

Series 9000-SAN

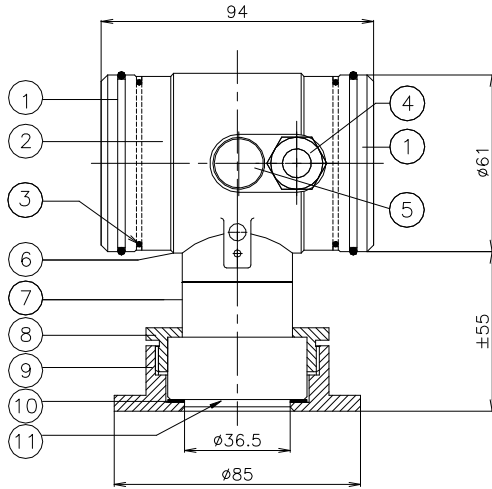

Description	Material
① Cover	SS 304
② Display with push buttons	
③ O-Ring	EPDM
④ PG-9 Cable Gland	
⑤ Venting	PA
⑥ Electronics housing	SS 304

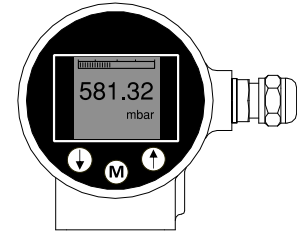

Front view: Transparent cover, option: I (extra price)

Description	Material
⑦ Foot	SS 316
⑧ Lock Ring	SS 304
⑨ Weld-on nipple	SS 316 L
⑩ Gasket	PTFE
⑪ Diaphragm	SS 316 L

Series 9000 - 1" BSP

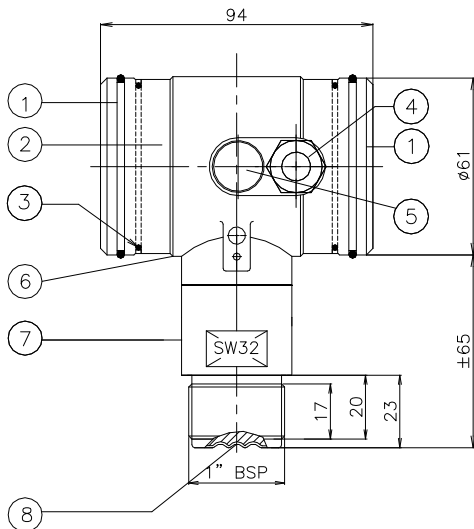

Description	Material
① Cover	SS 304
② Display with push buttons	
③ O-Ring	EPDM
④ PG-9 Cable Gland	

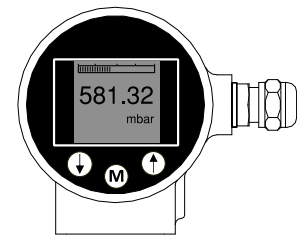

Front view: Transparent cover, option: I (extra price)

Description	Material
⑤ Venting	PA
⑥ Electronics housing	SS 304
⑦ Foot	SS 316
⑧ Diaphragm	SS 316 L

3. INSTALLING THE TRANSMITTER

The diaphragm of the transmitter is protected with a special protection cap. Protect the diaphragm until installation takes place. **Do not damage the diaphragm.**

3.1 INSTALLING WELD-ON NIPPLE

A certified welder should perform the installation of the weld-on nipple.

Weld with Argon, MIG or TIG, with the smallest welding pin possible.

1. Cut a hole in the process vessel or pipe for a precise fit of the weld-on nipple. The hole should be a tight fit when coupled with the weld-on nipple.
2. Prepare the hole by bevelling the edge to accept filler material.
3. Remove the weld-on nipple from the transmitter.

Remove the gasket and O-Ring out of the weld-on nipple!

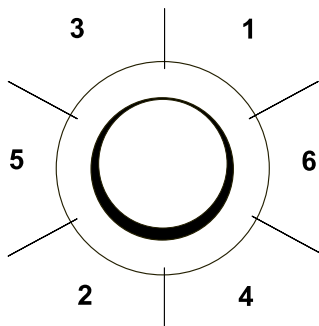

Improper installation may result in distortion of the weld-on nipple. Excessive heat will distort the weld-on nipple. Weld in sections as shown in the figure left. Allow adequate cooling between passes. To reduce the chances of distortion to the weld-on nipple, use a mandrel.

SERIES 9000-SAN: Part.no. 1019 – Art.no. 10230

Lockring Part.no. 1160 – Art.no. 10001

SERIES 9000:

Part.no. 1016 – Art.no. 10282

Determine (before welding) the position of the electronics housing, so that the cable entry and the venting are in the right position. After welding these positions are fixed.

4. Position the weld-on nipple in the vessel hole and tack six places. The weld sequence is shown in the figure above.
5. Weld the weld-on nipple in place using 0,03 to 0,045 in. (0,762 to 1,143 mm) stainless rod as filler material in the bevelled area. Adjust amperage for penetration.
6. Remove the mandrel after the welding operation.

3.2 INSTALLING TRANSMITTER SERIES 9000-SAN (Code W)

1. Make sure to correctly locate the packing within the weld-on nipple.
2. Improper installation of the packing can cause a process leak.
3. Position the transmitter into the weld-on nipple and begin engaging threads.
4. The transmitter can be rotated prior to seating enabling the user to optimize access to calibration adjustments, cable entry, and local indicator.
5. Once the Lock ring has been hand tightened, it must be tightened with an additional turn ($\pm 1/8''$) with adjustable pliers.

3.3 INSTALLING TRANSMITTER SERIES 9000 (Code W33)

1. After welding, clean up edges, and take care of the inside nipple wall.
2. Make sure the O-ring ⑩ is properly located.
3. Improper installation of the O-ring can cause a process leak.
4. Apply silicone grease to the O-ring ⑩, diaphragm ring and the hole inside wall of the weld-on nipple, this prevents galvanic cell corrosion between transmitter and the nipple inside.
5. Install the transmitter and fix it with the SS M8 bolt.

3.4 MOUNTING POSITION

When the transmitter is mounted horizontally, the cable gland must be pointed downwards.

3.5 MOUNTING POSITION EFFECT

All transmitters are calibrated in vertical position (diaphragm points downwards). If the transmitter is mounted in another position, there can be a little zero shift. (example 4,02 mA instead of 4,00 mA). After installation of the transmitter the zero must be set to 4,00 mA with P103 (cancel mounting position effect). This will not affect the span.

3.6 CALIBRATION

All transmitters are fully calibrated at the factory, to customer specified range. If the calibration is not specified, the transmitter will be calibrated at the maximum span.

3.7 CONNECTION TERMINAL

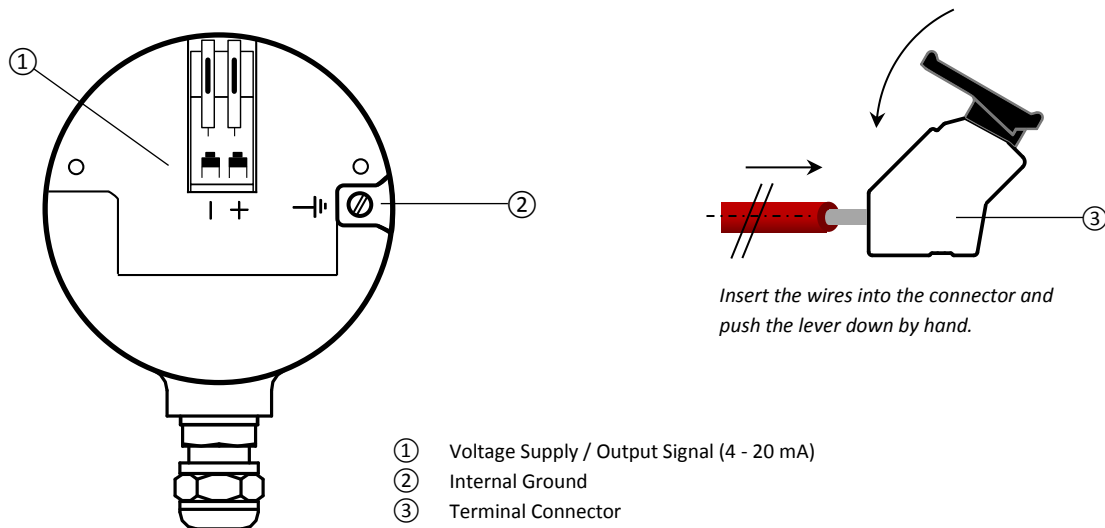

The figure above shows the wiring connection of the transmitter. The 2-wires must be connected to the terminal board. The wiring terminals can be operated without a screwdriver. The opening levers of the terminal can be lifted and pressed down by hand. Lift the opening levers of the terminals and insert the corresponding wires. Press down the levers by hand. The terminal spring will close and the wire is clamped.

3.8 WIRING

The transmitter must always be connected to ground. The transmitter must be connected with standard two-wire shielded cable. Do **not** run signal wiring in open trays with power wiring, or near heavy electrical equipment (Frequency controller or heavy pumps). Shielding must always be connected at the side of the power supply. In case the process connection is already connected to ground (e.g. via the tank or pipe line) do **not** connect the instrument to ground. Please ensure that the instrument is not connected to ground twice to prevent an 'earth loop'. In applications with synthetic process connections, the enclosure (internal or external) must be connected to ground.

Reversing the polarity will not damage the transmitter, but the transmitter will not function until the + and – are properly connected.



Please ensure that the transmitter is not connected to ground twice to prevent an earth loop.

4. REMAINING

4.2 CE / EMC-RULES

All Klay transmitters are manufactured in accordance with the RFI / EMC directives and comply with the CE standard. All transmitters are fitted with RFI filters, which provide optimum, trouble-free operation. Our products are in conformity with EMC-Directive 2014/30/EU based on test results using harmonized standards.



4.3 TRACEABILITY / YEAR OF MANUFACTURING

The year of manufacturing of the transmitter can be traced as follows: take the first three numbers from the serial number that is engraved in the transmitter and add 1100 to it.

Example: Serial Number 91602123. The year of manufacturing is $1100 + 916 = 2016$.

5. DISPLAY AND PUSH BUTTONS

The Series 9000 has a high contrast display for optimal readout. The menu is controlled by 3 pushbuttons. Navigate with the up and down through menus and measuring values. Enter a menu and confirm selections with the menu button.

-  Push the *up* button to browse through various menus and adjusting values.
-  Push the *down* button to browse through various menus and adjusting values.
-  Push the *menu* button to enter menus or confirm a selection.

Display Series 9000

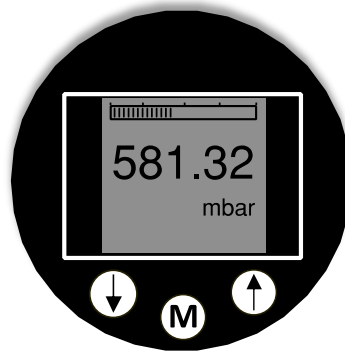

5.1 DISPLAY READOUT

When the transmitter is powered, a startup screen with the software version and the pressure range appears for a few seconds. After the startup screen the transmitter will automatically continue to the main screen with the actual measurement reading.

5.2 SUMMARY PROGRAMMING POINTS

PROGRAM POINT	NAME	FUNCTION
P100	Menu-Exit menu	Start and exit
P101	ZERO value	Zero adjustment (ZERO 4 mA) with or without test pressure
P102	SPAN value	Span adjustment (SPAN 20 mA) with or without test pressure
P103	MOUNT correction	Cancel mounting position effect
P104	UNITS	Selection of engineering units
P105	REVERSE mA	Output selection: 4-20 mA or 20-4 mA
P106	DAMPING	Adjustable damping: 0,00 till 25,00 seconds
P107	TEMP UNITS	Temperature unit selection: Celsius or Fahrenheit
P108	DEVICE SETUP	Configuration: Protection, HART, Display mode, Display update
P109	READOUT	Readout options on display: Current, Unit, percentage and temperature
P110	BURST MODE	Continuously broadcast a standard HART reply message

6. EXPLANATION PROGRAMMING POINTS

P101



Zero value

6.1 ZERO ADJUSTMENT (ZERO)

The transmitter is set to 0 mbar at atmospheric pressure.

The **ZERO** can be adjusted at a lower or higher point. This will be explained step by step by an example.

Example: Increase ZERO till 100 mBar.

1. The measuring unit of the transmitter is set to mBar. If not, this can be selected by choosing the right measuring unit in program point **P104**.
2. Navigate to program point **P101**, and push the menu button to enter the menu.
3. The actual measured value appear on the display.
4. Increase this value with the arrow  button to 100 mBar, and push the  button until save appear on the display.
5. The transmitter will return to the home screen. The measurement value at atmospheric pressure is now -100 mBar. At an applied pressure of 100 mbar the transmitter will display 0 mbar.

The transmitter can be adjusted to zero in a real process situation. The transmitter will measure the pressure in an actual process. This measurement will be used as the zero value (4 mA).

1. Go to the home screen, the transmitter will display the actual measured value.
2. Push the  button until the actual measured zero an the message **ZERO PUSHED** appear on the display.
3. The transmitter will return to home screen.

P102

Span value

6.2 SPAN ADJUSTMENT (SPAN)

This setting can be used to adjust the range (SPAN) according to an entered value or adjusted with or without an applied pressure. The maximum pressure which can be measured: The measurement at **ZERO (P101)** + the entered value **SPAN (P102)**. If the **ZERO (P101)** is increased, the maximum measured value will automatically be set higher at same rate as the zero. This will be explained step by step by an example.

Example: Measurement range 0 – 2000 mBar.

1. The **span** must be set at 2000 mBar
2. Navigate to program point **P102**, and push the menu button to enter the menu.
3. Adjust the **SPAN** with the push buttons to 2000 mBar and push the  button until save appear on the display.
4. The transmitter will return to the home screen.

The span can also be adjusted to a real process situation. The transmitter will measure the pressure in an actual process. This measurement will be used as the span value (20 mA).

1. Go to the home screen, the transmitter will display the actual measured value.
2. Push the  button until the actual measured span and the message **SPAN PUSHED** appear on the display.
3. The transmitter will return to home screen.



P102 is the adjustment of the total span.

When a compound range must be adjusted (for example -1 till +3 bar), a span of 4 bar must be programmed. The Zero (P101) must be set at -1 bar. The transmitter is adjusted at - **1 bar = Zero** and **+3 bar = Span**.

If the process temperature at -1 bar is above 20 °C another filling oil must be applied inside the transmitter (Option G26).

If the process temperature at -0,5 bar is above 60 °C another filling oil must be applied inside the transmitter (Option G26).

P103

Mount corr.

6.3 CANCEL MOUNTING POSITION EFFECT

All transmitters are calibrated vertically. If the transmitter is installed horizontally, the transmitter has a small "mounting position" effect on the zero. The pressure value displayed, will be for example 0,002 mbar instead of 0,000 mbar.

1. Navigate to program point **P103**, and push the menu button to enter the menu.
2. Two choices appear on the screen: **Set** and **Reset**.

Choosing **Set** will adjust the zero to 0,000 mbar in the mounting position when applicable.

- Select **Set**, and push the menu button to confirm.
- The corrected is value is shown on the display.
- Push the menu button to save.

Choosing **Reset** will put the transmitter back to factory setting. (vertical adjustment)

- Select **Reset**, and push the menu button to confirm to reset back to factory setting.
- The transmitter will return to the home screen.



Do not apply pressure when executing "Cancel mounting position effect"

P104

Units

6.4 DISPLAY SETTING OF UNITS

Various engineering units can be displayed on the display.

Factory setting = mbar

1. Navigate to program point **P104**, and push the menu button to enter the menu.
2. Several engineering units can be selected. Each selected engineering unit is automatically converted to the correct value of the corresponding unit.
3. Navigate through this menu and choose the required unit, push the menu button confirm.
4. The transmitter will return to the home screen. The measured reading will be displayed in the selected unit in the home screen.



The selected pressure unit is only visible on the display when UNITS is chosen in program point P109.

P105

Reverse mA

6.5 OUTPUT SELECTION 4-20 mA or 20-4 mA

Factory setting = 4 - 20 mA

1. Navigate to program point **P105**, and push the menu button to enter the menu.
2. Two choices appear on the screen: **4-20** and **20-4**
3. Make an output choice and push the menu button to confirm.
4. The transmitter will return to the home screen.

P106

Damping

6.6 DAMPING ADJUSTMENT

The transmitter has an adjustable damping between 0,00 to 25,00 seconds.

Factory setting = 0,00 seconds

1. Navigate to program point **P106**, and push the menu button to enter the menu.
2. Two choices appear on the screen: **Set** and **Reset**
 Choosing **Set** allows a value to be set between 0,00 and 25,00 seconds.
 - Select **Set**, and push the menu button to confirm.
 - Adjust the damping with the push buttons and push the menu button to confirm.
 - The transmitter will return to the home screen.
 Choosing **Reset** will put the transmitter back to factory setting (0,00 seconds)
 - Select **Reset**, and push the menu button to confirm to reset back to factory setting.
 - The transmitter will return to the home screen.

P107

Temp Units

6.7 TEMPERATURE UNITS

In this menu the preferred temperature unit can be selected.

1. Navigate to program point **P107**, and push the menu button to enter the menu.
2. Two choices appear on the screen: **Celsius** and **Fahrenheit**.
3. Make a choice and push the menu button to confirm.
4. The transmitter will return to the home screen.

P108

Device Setup

6.8 DEVICE SETUP

In this menu, several operational settings can be made for the transmitter and the display.

1. Navigate to program point **P108**, and push the menu button to enter the menu.
2. Five choices appear on the screen:
 - LocProtect** : The transmitter can be protected against local adjustments
 - ComProtect** : The transmitter can be protected against adjustments with HART.
 - HART** : Option for HART® 5 and HART® 7 communication.
 - DispMode** : Option for turning the display **on** or **off**.
 - Disp.Upd.**: Option to adjust the refresh rate of the measuring value on the display between 0,0 to 5,0 seconds. For example when this value is set to 2,0 seconds, the measuring value on the display will be refreshed every 2 seconds.
 - Select **Set**, and push the menu button to confirm.
 - Adjust the setting with the push buttons and confirm with the menu button.
 - The transmitter will return to the home screen.
 - Choosing **Reset** will put the transmitter back to factory setting (0,0 seconds).

P109

Readout

6.9 READOUT

In this menu, the type of readout on the display can be adjusted.

Factory Setting = Unit

1. Navigate to program point **P109**, and push the menu button to enter the menu.
2. Four choices appear on the screen:
 - Current** : Current value (4 - 20 mA)
 - Unit** : Pressure unit (Selected in **P104**)
 - Percentage** : 0 - 100%

Temperature : Actual process temperature (°C or F)

3. Navigate to the desired choice, confirm by pushing the menu button.
4. The transmitter will return to the home screen.

P110

Burst mode

6.10 BURST MODE (HART®)

The transmitter (Only when HART® is present) can be configured for Burst mode. This will enable continuously broadcasting standard HART® reply messages.

1. Navigate to program point **P110**, and push the menu button to enter the menu.
2. Five choices appear on the screen: **Mode Cntrl**, **Cmd number**, **Message**, **Period** and **Trigger**
3. Select **Mode Cntrl**, and push to confirm.
4. Two choices appear on the screen: **“On”** and **“Off”**
 - Choose **On** to turn on burst mode.
 - Choose **Off** to turn off burst mode.
5. Select **Message** to select the burst message 0,1,2 or 3 and push the menu button to confirm.
6. Select **Cmd number**, and push the menu button to confirm.

Five choices appear on the screen:

- **Cmd 01** = PRIMARY VARIABLE
- **Cmd 02** = CURRENT AND PERCENT OF RANGE
- **Cmd 03** = DYNAMIC VARIABLES AND CURRENT
- **Cmd 09** = DEVICE VARIABLES WITH STATUS
- **Cmd 48** = ADDITIONAL TRANSMITTER STATUS

Choose the preferable burst mode, and push menu button to confirm.

7. Select **Period**, and push the menu button to confirm.

Two choices appear on the screen: **“Max Time”** and **“Min Time”**

- Select **Max Time** to set the maximum amount of time when the message will be send. This value can be set from 0.5 to 3600 seconds.
- Select **Min Time** to set the minimum amount of time when the message will be send. This value can be set from 0.5 to 3600 seconds.

Enter the preferred value, and push the menu button to confirm.

8. Select **Trigger**, and push the menu button to confirm.

9. Five choices appear on the screen:

Continuous = The Burst message is send continuously.

Windowed = The Burst message is triggered when the measured value deviates more than the specified trigger value.

Rising = The Burst message is triggered when the measured value rises above the triggered value.

Falling = The Burst message is triggered when the measured value falls below the triggered value.

On-Change = The Burst message is triggered when any value in the measuring changing.

Choose the desired burst mode, and set the preferred parameters.

P111

Information

6.11 INFORMATION

This menu summarizes information about the configuration of the transmitter.

Below the

V No:	Software Version number	Tunit:	Temperature unit (°C or F)
No:	Serial number of the transmitter	Tph:	Highest measured process temperature
Z:	Zero adjustment	Tpl:	Lowest measured process temperature
S:	Span adjustment	Tah:	Highest measured ambient temperature
Da:	Out delay on display	Tal:	Lowest measured ambient temperature
O:	Output (4-20 mA or 20-4 mA)	Tc no:	Tag number
Lpro:	Local protection (on/off)		

7. PROGRAMMING THE SERIES 9000

7.1 PROGRAMMING WITH HAND HELD TERMINAL



When using HART® or a Hand Held Terminal (HHT), a minimum resistance of **250 Ω** must be present in the loop of the 2-wire system. This is necessary for proper communication (see drawing below). A power supply of at least **17 Vdc** must be used.

The Series 9000 can easily be programmed with the Hand Held Terminal (HHT) from the HART® Foundation (type 275 or 375 HART® Communicator).

Option 1: HART® Handheld terminal connected across the transmitter.

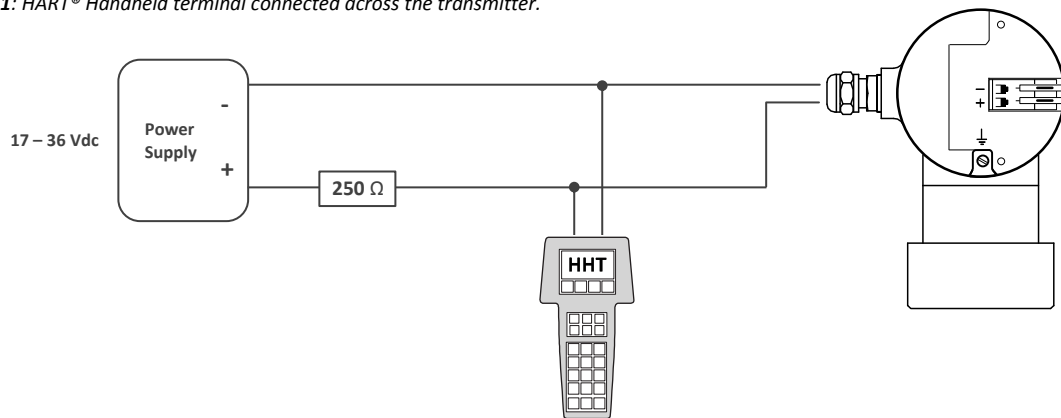

Option 2: HART® Handheld terminal connected across the loop resistor.

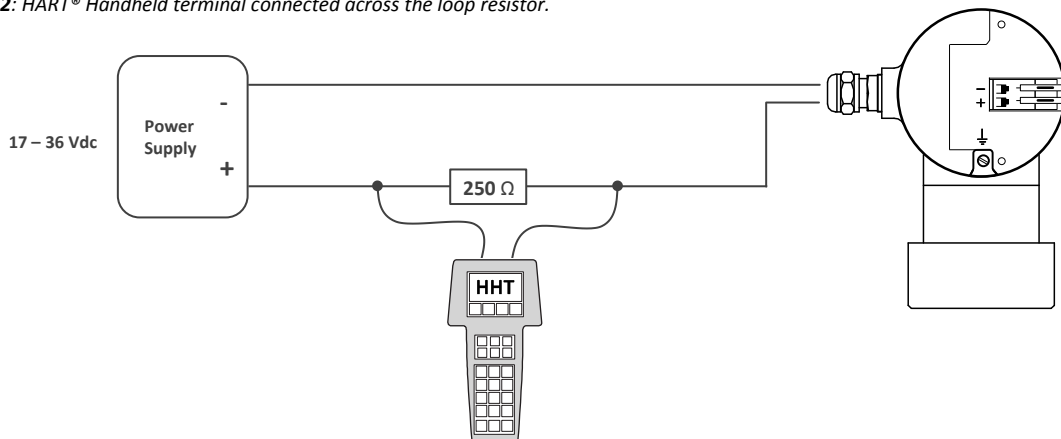

9. SPECIFICATIONS

Manufacturer		Klay Instruments B.V.		
Instrument		Series 9000 and Series 9000-SAN		
Output		4-20 mA Option: HART® Protocol		
Power Supply		Standard : 12 – 36 Vdc HART® : 17 – 36 Vdc (Standard) min. 250 Ω		
Accuracy		0,2 % - (Turn down 4:1) (Option: 0,1 %)		
Ranges¹	Code	Adjustable span ranges		Max. overpressure
		Min	Max	
Series 9000 and 9000-SAN	A	0 - 0,04 bar	0 - 0,1 bar	6,4 bar
	B	0 - 0,1 bar	0 - 0,4 bar	6,4 bar
	D	0 - 0,4 bar	0 - 1,6 bar	10,5 bar
	E	0 - 1,0 bar	0 - 4,0 bar	16 bar
	F	0 - 2,0 bar	0 - 10 bar	30 bar
	G	0 - 6,0 bar	0 - 24 bar	100 bar
	H	0 - 20 bar	0 - 80 bar ²	200 bar
	Process Temperature Series 9000		-20 °C to +80 °C (-4 °F to 176 °F)	
Process Temperature Series 9000-SAN ³		-20 °C to +100 °C (-4 °F to 212 °F) 145 °C / 45 min		
Ambient Temperature Series 9000 and 9000-SAN		-20 °C to +70 °C (-4 °F to 158 °F)		
Damping		0,00 seconds to 25,00 seconds Standard: 0,00 seconds.		
Protection Grade		IP66		
Material		Housing "wetted" parts	AISI 304 (Optional AISI 316) AISI 316 L (Other materials on request)	

1: For vacuum applications and compound ranges in combination with higher process temperatures a special oil filling must be applied (Option G26).

2: For pressures higher than 80 bar, contact Klay Instruments for information.

3: For higher temperatures use Klay option HT (High Temperature), contact Klay Instruments for information.

10. PRECAUTIONS AND WARNINGS

- Check if the specifications of the transmitter meet the needs of the process conditions
- When the Series 9000 (SAN) is used as a level transmitter, be aware of the place where the transmitter is mounted. Here are some suggestions:
 - DO NOT mount a level transmitter in- or near filling or discharging pipes.
 - In case of automatic cleaning systems or hand cleaning: never point the water jets on the diaphragm, take necessary steps to avoid this. Guarantee will not be granted.
- When the Series 9000 is used as a pressure transmitter, be aware of the following points:
 - Rapid closing valves in combination with high flow velocity will cause water hammer(spikes) and can destroy the transmitter. DO NOT mount a transmitter near such valves, always a few pipe bends away up or down stream (avoid suction).
 - Install a pressure transmitter a few pipe bends away from pumps, as well on the suction or pressure side of the pump
- **WELDING INFORMATION:**
When using the Series 9000 or 9000-SAN code "W" the welding information on page 5 must be followed exactly. This is very important to prevent distortion of the weld-on nipples. It also prevents the screw thread from the Series 9000-SAN (M56 x 1,25) from being deformed.
- The diaphragm of the transmitter is protected with a special protection cap. Protect the diaphragm until installation takes place, to prevent damaging of the diaphragm.
- Configuring the transmitter local and remote simultaneously will cause transmission errors and must be prevented.
- As soon as the wiring is brought inside through the cable gland and connected to the terminal board, make sure the cable gland is tightly fixed, so that moisture cannot enter into the electronics housing.
- Avoid high pressure water-jets pointed at the venting.
- If the ambient conditions are very wet, we advise to use a venting through the cable. A special vented cable can be connected on request. (The normal venting will be removed) In that case the transmitter is IP68.
- The covers must be fully engaged, so that moisture cannot ingress into the electronics housing.
- **WARRANTY:** The warranty is 1 year from delivery date.
Klay Instruments B.V. does not accept liability for consequential damage of any kind due to use or misuse of the Series 9000. Warranty will be given, to be decided by the manufacturer. For evaluation and repair the transmitter must be shipped prepaid to the factory on manufacturers authorization.
- **NOTE:** Klay Instruments B.V. reserves the right to change its specifications at any time, without notice. Klay Instruments B.V. is not an expert in the customer's process (technical field) and therefore does not warrant the suitability of its product for the application selected by the customer.

Manufactured by:

KLAY-INSTRUMENTS B.V.
www.klay.nl

Nijverheidsweg 5
P.O. Box 13
Tel: +31-521-591550
Fax: +31 -521-592046

7991 CZ DWINGELOO
7990 AA DWINGELOO
The Netherlands
E-mail: info@klay.nl