

Product manual

5335

***2-wire transmitter with
HART protocol***



UK
CA



2-wire transmitter with HART protocol 5335

Table of contents

Application	4
Technical characteristics	4
Mounting / installation	4
Order	5
Electrical specifications	5
Accessories	5
Connections	8
Block diagram	8
Programming	9
Connection of transmitters in multidrop mode	10
Mechanical specifications	10
Mounting of sensor wires	10
ATEX Installation Drawing - 5335A	11
ATEX Installation Drawing - 5335D	13
IECEX Installation Drawing - 5335A	15
IECEX Installation Drawing - 5335D	17

2-wire transmitter with HART protocol 5335

- RTD, TC, Ohm, or mV input
- Extremely high measurement accuracy
- HART communication
- Galvanic isolation
- For DIN form B sensor head mounting

Application

- Linearised temperature measurement with Pt100... Pt1000, Ni100...Ni1000, or TC sensor.
- Difference or average temperature measurement of 2 resistance or TC sensors.
- Conversion of linear resistance variation to a standard analog current signal, for instance from valves or Ohmic level sensors.
- Amplification of a bipolar mV signal to a standard 4...20 mA current signal.
- Connection of up to 15 transmitters to a digital 2-wire signal with HART communication.

Technical characteristics

- Within a few seconds the user can program PR5335 to measure temperatures within all ranges defined by the norms.
- The RTD and resistance inputs have cable compensation for 2-, 3- and 4-wire connection.
- The 5335 has been designed according to strict safety requirements and is thus suitable for application in SIL installations.
- Continuous check of vital stored data for safety reasons.
- Sensor error detection according to the guidelines in NAMUR NE 89.

Mounting / installation

- For DIN form B sensor head mounting. In non-hazardous areas the 5335 can be mounted on a DIN rail with the PR fitting type 8421.

Applications

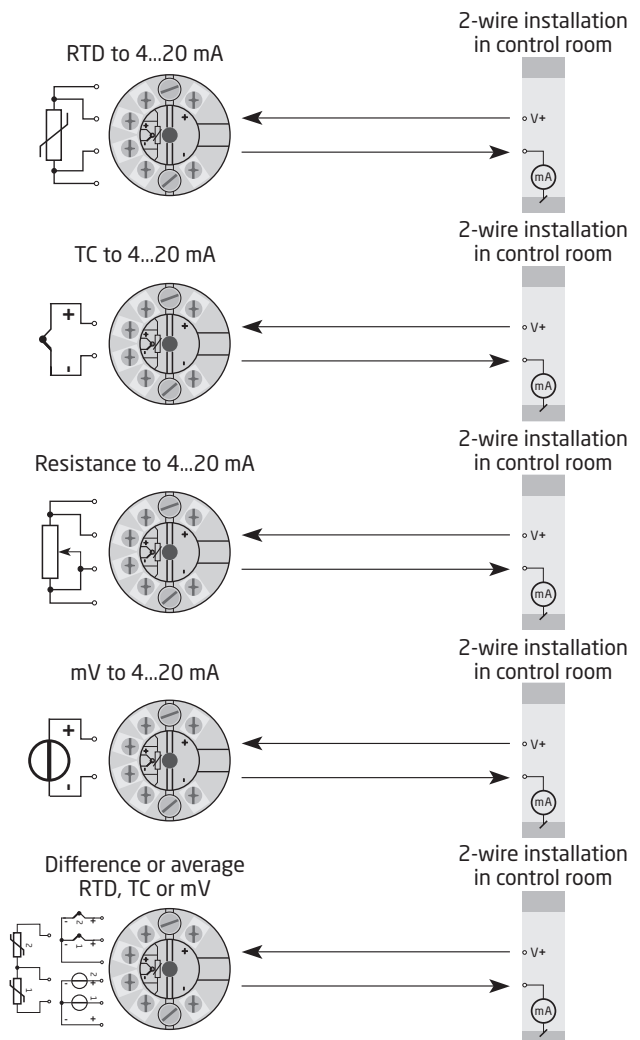

Order

Type	Version
5335	Zone 2 / Div. 2 : A
	Zone 0, 1, 2, 21, 22, M1 / DIV. 1, DIV. 2 : D

Accessories

5909 = Loop Link USB interface and PReset Software
8421 = DIN rail clip

Electrical specifications

Environmental conditions:

Operating temperature -40°C to +85°C
Calibration temperature. 20...28°
Humidity. < 95% RH (non-cond.)
Protection degree (encl./terminal) IP68/IP00

Mechanical specifications:

Dimensions Ø 44 x 20.2 mm
Weight approx. 50 g
Max. wire size. 1 x1.5 mm² stranded wire
Screw terminal torque. 0.4 Nm
Vibration. IEC 60068-2-6
 2...25 Hz. ±1.6 mm
 25...100 Hz ±4 g

Common specifications:

Supply voltage, DC
 5335A 8.0...35 VDC
 5335D 8.0...30 VDC
Internal power dissipation
 5335A 25 mW...0.8 W
 5335D 25 mW...0.7 W
Isolation voltage, test / operation. 1.5 kVAC / 50 VAC
Warm-up time. 30 s
Programming Loop Link & HART
Signal / noise ratio Min. 60 dB
Response time (programmable) 1...60 s
EEPROM error check < 10 s
Signal dynamics, input 22 bit
Signal dynamics, output 16 bit
Effect of supply voltage variation. < 0.005% of span / VDC

Accuracy, the greater of general and basic values:

General values		
Input type	Absolute accuracy	Temperature coefficient
All	$\leq \pm 0.05\%$ of span	$\leq \pm 0.005\%$ of span / °C

Basic values		
Input type	Basic accuracy	Temperature coefficient
Pt100 & Pt1000	$\leq \pm 0.1^\circ\text{C}$	$\leq \pm 0.005^\circ\text{C}/^\circ\text{C}$
Ni100	$\leq \pm 0.2^\circ\text{C}$	$\leq \pm 0.005^\circ\text{C}/^\circ\text{C}$
Lin. R	$\leq \pm 0.1 \Omega$	$\leq \pm 5 \text{ m}\Omega / ^\circ\text{C}$
Volt	$\leq \pm 10 \mu\text{V}$	$\leq \pm 0.5 \mu\text{V} / ^\circ\text{C}$
TC type: E, J, K, L, N, T, U	$\leq \pm 0.5^\circ\text{C}$	$\leq \pm 0.025^\circ\text{C} / ^\circ\text{C}$
TC type: B, R, S, W3, W5	$\leq \pm 1^\circ\text{C}$	$\leq \pm 0.1^\circ\text{C} / ^\circ\text{C}$

EMC - immunity influence.	$< \pm 0.1\%$ of span
Extended EMC immunity: NAMUR NE 21, A criterion, burst	$< \pm 1\%$ of span

Electrical specifications, input:

Max. offset 50% of selec. numerical max. value

RTD and linear resistance input:

RTD type	Min. value	Max. value	Min. span	Standard
Pt100	-200°C	+850°C	10°C	IEC 60751
Ni100	-60°C	+250°C	10°C	DIN 43760
Lin. R	0 Ω	7000 Ω	25 Ω	-----

Cable resistance per wire (max.). 5 Ω

(up to 50 Ω per wire is possible with reduced measurement accuracy)

Sensor current Nom. 0.2 mA

Effect of sensor cable resistance (3- / 4-wire) $< 0.002 \Omega/\Omega$

Sensor error detection Yes

Short circuit detection. If 0% > 30 Ω

TC input:

Type	Min. temperature	Max. temperature	Min. span	Standard
B	+400°C	+1820°C	100°C	IEC584
E	-100°C	+1000°C	50°C	IEC584
J	-100°C	+1200°C	50°C	IEC584
K	-180°C	+1372°C	50°C	IEC584
L	-100°C	+900°C	50°C	DIN 43710
N	-180°C	+1300°C	50°C	IEC584
R	-50°C	+1760°C	100°C	IEC584
S	-50°C	+1760°C	100°C	IEC584
T	-200°C	+400°C	50°C	IEC584
U	-200°C	+600°C	50°C	DIN 43710
W3	0°C	+2300°C	100°C	ASTM E988-90
W5	0°C	+2300°C	100°C	ASTM E988-90

Cold junction compensation	< ±1.0°C
External CJC with Ni100 or Pt100	-40 ≤ T _{amb.} ≤ 135°C
Sensor error detection	Yes
Sensor error current:	
When detecting	Nom. 33 µA
Else.	0 µA
Short circuit detection.	No
Voltage input:	
Measurement range	-800...+800 mV
Min. span	2.5 mV
Input resistance	10 MΩ
Current output:	
Signal range.	4...20 mA
Min. signal range.	16 mA
Updating time	440 ms
	(660 ms for diff.)
Fixed output signal	Between 4 and 20 mA
Output signal at EEprom error	≤ 3.5 mA
Load resistance.	≤ (V _{supply} - 8.0) / 0.023 [Ω]
Load stability.	< ±0.01% of span / 100 Ω
Sensor error detection:	
Programmable	3.5...23 mA
(shorted sensor error detection is ignored at TC and mV input)	
NAMUR NE43 Upscale	23 mA
NAMUR NE43 Downscale.	3.5 mA

of span = of the presently selected range

Observed authority requirements:

EMC.	2014/30/EU & UK SI 2016/1091
ATEX	2014/34/EU & UK SI 2016/1107
RoHS	2011/65/EU & UK SI 2012/3032
EAC	TR-CU 020/2011
EAC Ex	TR-CU 012/2011

Approvals:

DNV, Ships & Offshore.	TAA0000101
--------------------------------	------------

I.S. / Ex approvals:

5335A:	
ATEX.	DEKRA 20ATEX0109 X
5335D:	
ATEX.	DEKRA 20ATEX0108 X
FM	FM17US0013X
5335A & 5335D:	
IECEX.	DEK 20.0063X
CSA.	1125003
INMETRO	DEKRA 18.0002X
EAC Ex.	RU C-DK.HA65.B.00355/19

Functional Safety:

Hardware assessed for use in SIL applications
 FMEDA report - www.prelectronics.com

Connections

Input:

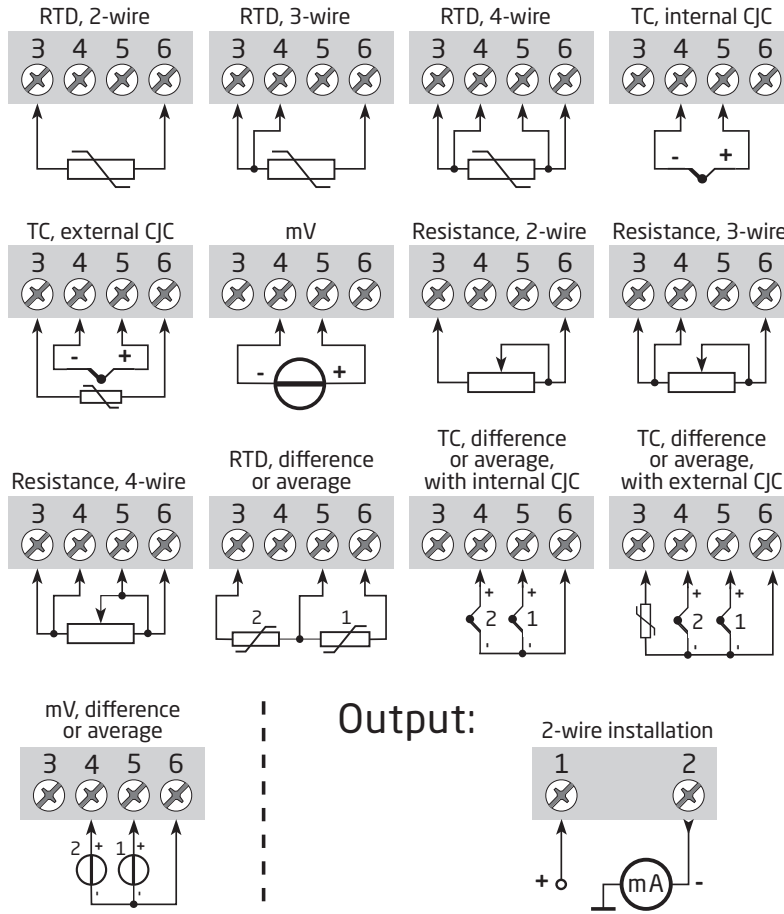

Output:

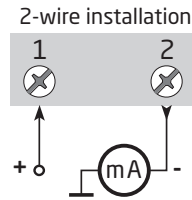

Block diagram

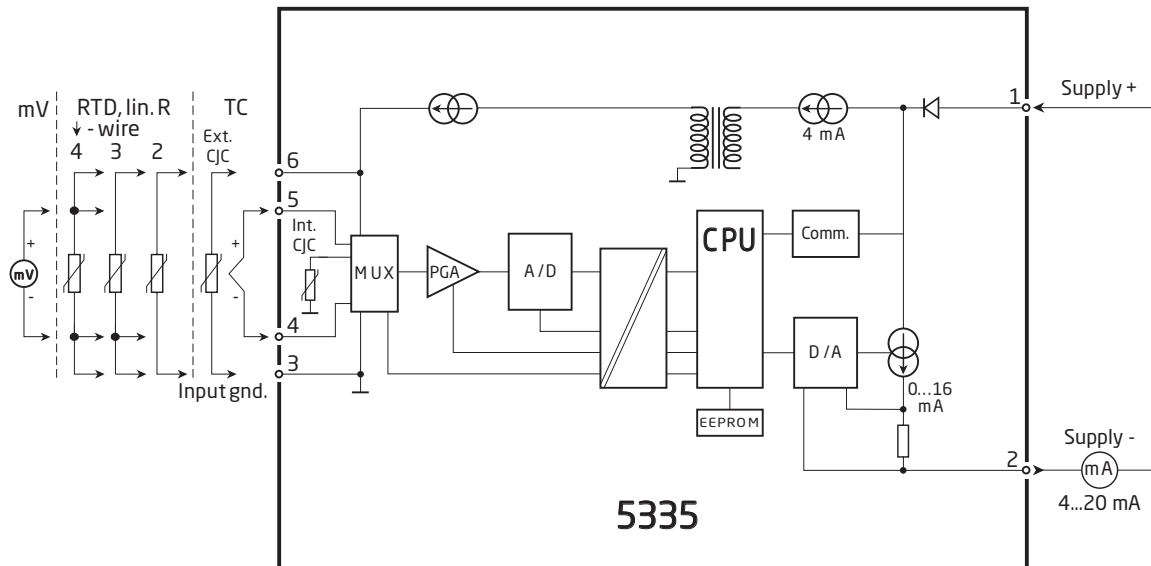

Programming

5335 can be configured in the following 3 ways:

1. With PR electronics A/S' communications interface Loop Link and PReset PC configuration software.
2. With a HART modem and PReset PC configuration software.
3. With a HART communicator with PR electronics A/S' DDL driver.

1: Loop Link

For programming please refer to the drawing below and the help functions in PReset.

Loop Link is not approved for communication with devices installed in hazardous (Ex) area.

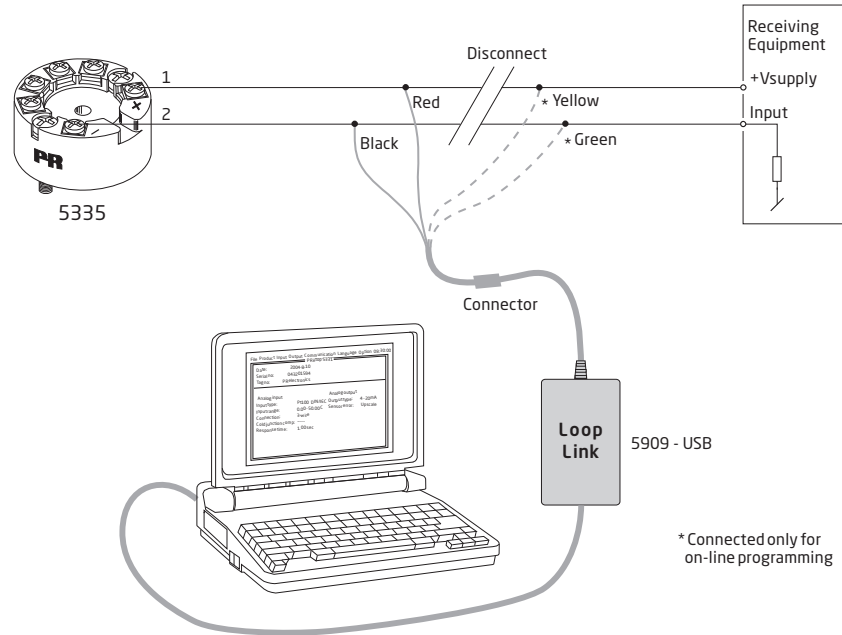

2: HART modem

For programming please refer to the drawing below and the help functions in PReset.

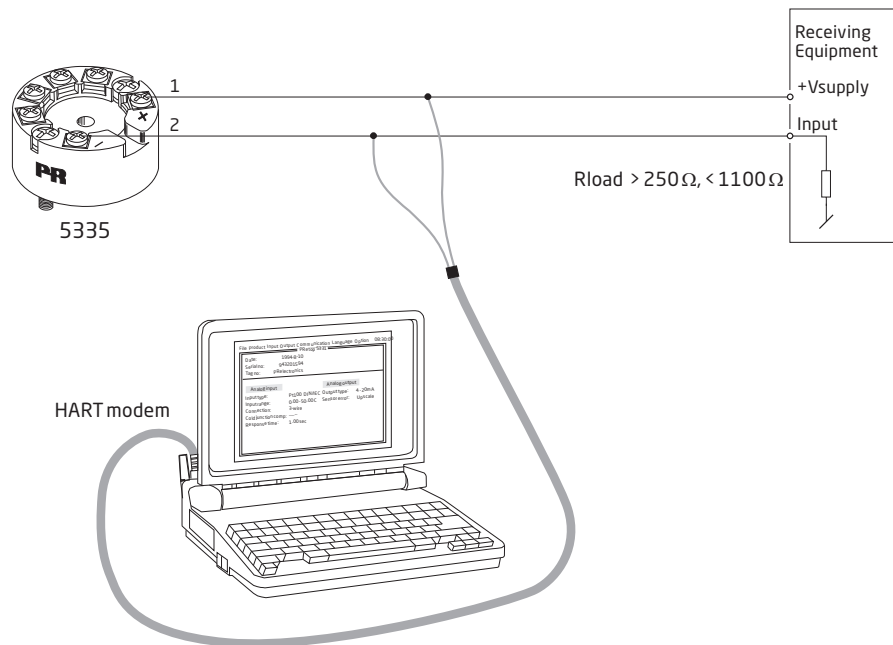

3: HART communicator

For programming please refer to the drawing below. To get access to productspecific commands, the HART communicator must be loaded with the PR electronics A/S DDL driver. This can be ordered either at the HART Communication Foundation or PR electronics A/S.

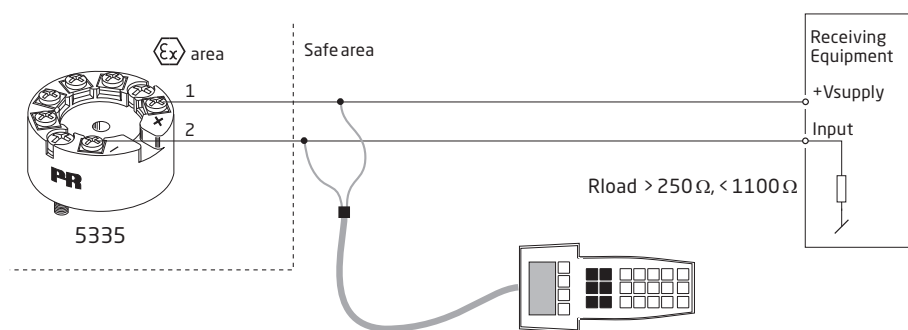

Connection of transmitters in multidrop mode

- The HART communicator or a PC modem can be connected across AB or BC.

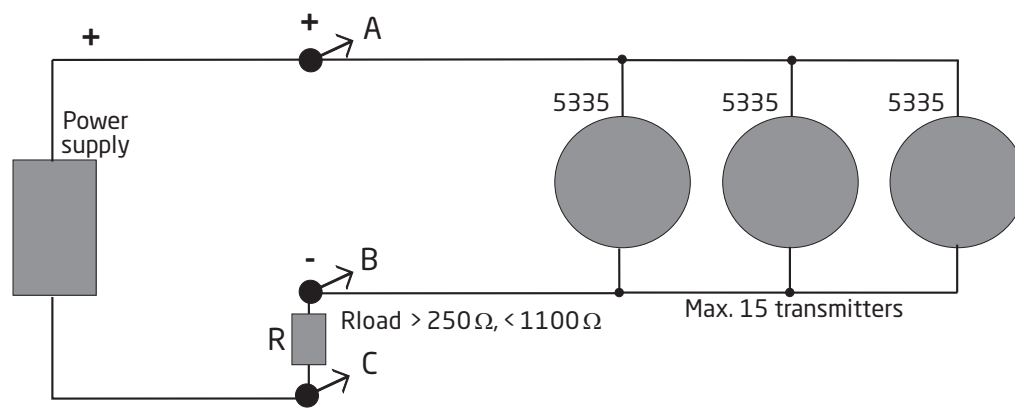

- The outputs of max. 15 transmitters can be connected in parallel for a digital HART communication on 2-wires.
- Before it is connected, each transmitter must be configured with a unique number from 1 to 15. If 2 transmitters are configured with the same number, both will be excluded. The transmitters must be programmed for multidrop mode (with a fixed output signal of 4 mA). Maximum current in the loop is therefore 60 mA.
- The communication is either by means of a HART communicator or a HART modem.
- The PRreset PC configuration software can configure the individual transmitter for multidrop mode and provide it with a unique polling address.

Mechanical specifications

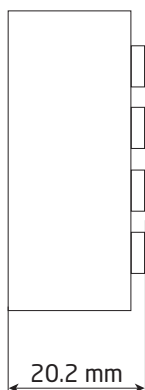
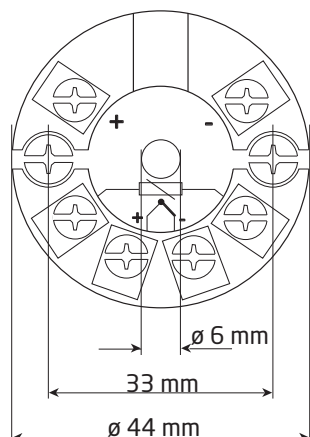

Mounting of sensor wires

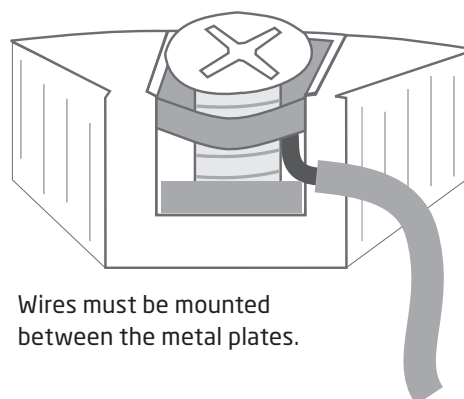

ATEX-installation drawing 5335QA02-V5R0

For safe installation of 5335A and 5337A the following must be observed. The module shall only be installed by qualified personnel who are familiar with the national and international laws, directives and standards that apply to this area. Year of manufacture can be taken from the first two digits in the serial number.

ATEX Certificate DEKRA 20ATEX0109 X

Marking



II 3 G Ex nA [ic] IIC T6 ... T4 Gc
 II 3 G Ex ec [ic] IIC T6 ... T4 Gc
 II 3 G Ex ic IIC T6 ... T4 Gc
 II 3 D Ex ic IIIC Dc

Standards

EN 60079-0: 2018, EN 60079-11: 2012,
 EN 60079-15: 2010, EN 60079-7:2015 +A1: 2018

Terminal 3,4,5,6	Terminal 1,2	Terminal 1,2	Terminal 1,2
Ex ic IIC, Ex ic IIIC	Ex ic IIC, Ex ic IIIC	Ex ic IIC, Ex ic IIIC	Ex nA, Ex ec
Uo: 9.6 V Io: 28 mA Po: 67 mW Lo: 35 mH Co: 3.5 μF	Ui = 35 V Ii = 110 mA Ci = 1 nF Li = 0 μH	Ui = 24 V Ii = 260 mA Ci = 1 nF Li = 0 μH	Umax ≤ 35 VDC or Umax ≤ 24 VDC

Ex ic IIC, Ex ic IIIC Temperature Class	Ambient temperature range	
	Ui=35 V	Ui=24 V
T6	-40°C to +54°C	-40°C to +63°C
T5	-40°C to +69°C	-40°C to +78°C
T4	-40°C to +85°C	-40°C to +85°C

Ex ec, Ex nA Temperature Class	Ambient temperature range	
	Vmax=35 V	Vmax=24 V
T6	-40°C to +43°C	-40°C to +55°C
T5	-40°C to +85°C	-40°C to +85°C
T4	-40°C to +85°C	-40°C to +85°C

Installation notes

If the enclosure is made of non-metallic plastic materials, electrostatic charges on the transmitter enclosure shall be avoided.

If the transmitter is installed in an explosive atmosphere requiring the use of equipment protection level Gc and applied in type of protection Ex ic, the transmitter shall be mounted in an enclosure that provides a degree of protection of at least IP20 according to EN 60259, and that is suitable for the application and correctly installed.

If the transmitter is installed in an explosive atmosphere requiring the use of equipment protection level Dc, the transmitter shall be mounted in a separately certified enclosure that provides a degree of protection of at least IP5X according to EN 60079-0, and that is suitable for the application and correctly installed. The surface temperature of the outer enclosure is +20 K above the ambient temperature, determined without a dust layer. Ambient temperature range: -40°C to +85°C.

If the transmitter is installed in an explosive atmosphere requiring the use of equipment protection level Gc and applied in type of protection Ex nA or Ex ec, the transmitter shall be mounted in a separately certified enclosure that provides a degree of protection of at least IP54 according to EN 60079-0, and that is suitable for the application and correctly installed.

If the transmitter is installed in an explosive atmosphere requiring the use of equipment protection level Gc and applied in type of protection Ex nA or Ex ec, the equipment shall only be used in an area of not more than pollution degree 2, as defined in EN 60664-1.

ATEX-installation drawing 5335QA01-V5R0



For safe installation of 5335D or 5337D the following must be observed. The module shall only be installed by qualified personnel who are familiar with the national and international laws, directives and standards that apply to this area. Year of manufacture can be taken from the first two digits in the serial number.

ATEX Certificate DEKRA 20ATEX0108 X

Marking



II 1 G Ex ia IIC T6...T4 Ga
II 2 D Ex ia IIIC Db
I M1 Ex ia I Ma

Standards EN IEC 60079-0: 2018, EN 60079-11: 2012

Hazardous area
Zone 0, 1, 2, 21, 22

Non Hazardous Area

Terminal: 3,4,5,6

Uo: 9.6 VDC
Io: 28 mA
Po: 67 mW
Lo: 35 mH
Co: 3.5 µF

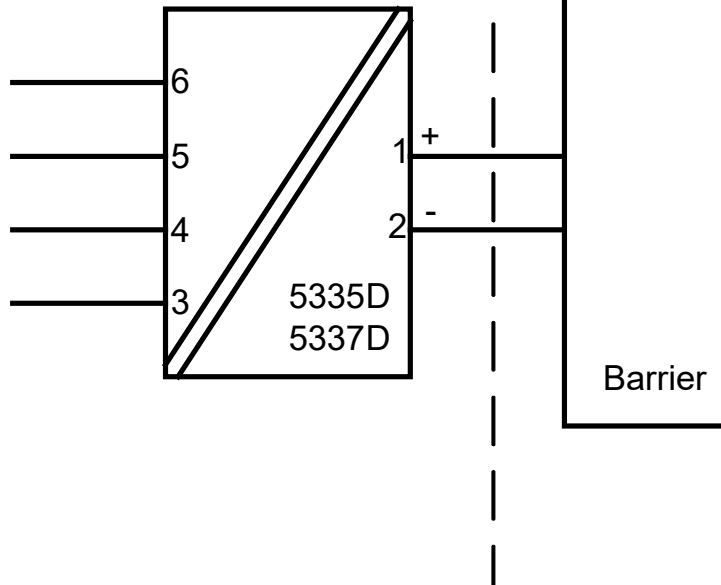

Terminal: 1,2

Ui: 30 VDC li: 120 mA Pi: 0.84 W or Pi: 0.75 W
Li: 0 µH Ci: 1.0 nF

Temperature Class	Ambient temperature range	
	Pi: 0.84 W	Pi: 0.75 W
T6	-40°C to +47°C	-40°C to +50°C
T5	-40°C to +62°C	-40°C to +65°C
T4	-40°C to +85°C	-40°C to +85°C

Installation notes

If the enclosure is made of non-metallic plastic materials, electrostatic charges on the transmitter enclosure shall be avoided.

If the transmitter is installed in an explosive atmosphere requiring the use of equipment protection level Ga, the transmitter shall be mounted in an enclosure that provides a degree of protection of at least IP20 according to EN 60529, and that is suitable for the application and correctly installed.

If the transmitter is installed in an explosive atmosphere requiring the use of equipment protection level Ga or Ma, and if the enclosure is made of aluminum, it must be installed such, that ignition sources due to impact and friction sparks are excluded.

If the transmitter is installed in an explosive atmosphere requiring the use of equipment protection level Db, the transmitter shall be mounted in a separately certified enclosure that provides a degree of protection of at least IP5X according to EN 60079-0, and that is suitable for the application and correctly installed. The surface temperature of the outer enclosure is +20 K above the ambient temperature, determined without a dust layer.
Ambient temperature range: -40°C to +85°C.

If the transmitter is installed in an explosive atmosphere requiring the use of equipment protection level Ma, the transmitter shall be mounted in an enclosure that provides a degree of protection of at least IP54 according to EN 60529, and that is suitable for the application and correctly installed.
Ambient temperature range: -40°C to +85°C.

Cable entries and blanking elements shall be used that are suitable for the application and correctly installed.

For an ambient temperature $\geq 60^{\circ}\text{C}$, heat resistant cables shall be used with a rating of at least 20 K above the ambient temperature.

The sensor circuit is not infallibly galvanically isolated from the input circuit. However, the galvanic isolation between the circuits is capable of withstanding a test voltage of 500 VAC for 1 minute.

IECEX-installation drawing 5335QI02-V5R0

For safe installation of 5335A and 5337A the following must be observed. The module shall only be installed by qualified personnel who are familiar with the national and international laws, directives and standards that apply to this area. Year of manufacture can be taken from the first two digits in the serial number.

Certificate	IECEX DEK 20.0063X
Marking	Ex nA [ic] IIC T6 ... T4 Gc Ex ec [ic] IIC T6 ... T4 Gc Ex ic IIC T6 ... T4 Gc Ex ic IIIC Dc
Standards	IEC 60079-0: 2017, IEC 60079-11: 2011, IEC 60079-15: 2010, IEC 60079-7:2017

Terminal 3,4,5,6	Terminal 1,2	Terminal 1,2	Terminal 1,2
Ex ic IIC, Ex ic IIIC	Ex ic IIC, Ex ic IIIC	Ex ic IIC, Ex ic IIIC	Ex nA, Ex ec
Uo: 9.6 V Io: 28 mA Po: 67 mW Lo: 35 mH Co: 3.5 μ F	Ui = 35 V Ii = 110 mA Ci = 1 nF Li = 0 μ H	Ui = 24 V Ii = 260 mA Ci = 1 nF Li = 0 μ H	Umax \leq 35 VDC or Umax \leq 24 VDC

Ex ic IIC, Ex ic IIIC Temperature Class	Ambient temperature range	
	Ui=35 V	Ui=24 V
T6	-40°C to +54°C	-40°C to +63°C
T5	-40°C to +69°C	-40°C to +78°C
T4	-40°C to +85°C	-40°C to +85°C

Ex ec, Ex nA Temperature Class	Ambient temperature range	
	Vmax=35 V	Vmax=24 V
T6	-40°C to +43°C	-40°C to +55°C
T5	-40°C to +85°C	-40°C to +85°C
T4	-40°C to +85°C	-40°C to +85°C

Installation notes

If the enclosure is made of non-metallic plastic materials, electrostatic charges on the transmitter enclosure shall be avoided.

If the transmitter is installed in an explosive atmosphere requiring the use of equipment protection level Gc and applied in type of protection Ex ic, the transmitter shall be mounted in an enclosure that provides a degree of protection of at least IP20 according to IEC 60259, and that is suitable for the application and correctly installed.

If the transmitter is installed in an explosive atmosphere requiring the use of equipment protection level Dc, the transmitter shall be mounted in a separately certified enclosure that provides a degree of protection of at least IP5X according to IEC 60079-0, and that is suitable for the application and correctly installed. The surface temperature of the outer enclosure is +20 K above the ambient temperature, determined without a dust layer.
Ambient temperature range: -40°C to +85°C.

If the transmitter is installed in an explosive atmosphere requiring the use of equipment protection level Gc and applied in type of protection Ex nA or Ex ec, the transmitter shall be mounted in a separately certified enclosure that provides a degree of protection of at least IP54 according to IEC 60079-0, and that is suitable for the application and correctly installed.

If the transmitter is installed in an explosive atmosphere requiring the use of equipment protection level Gc and applied in type of protection Ex nA or Ex ec, the equipment shall only be used in an area of not more than pollution degree 2, as defined in IEC 60664-1.

IECEX-installation drawing 5335QI01-V5R0



For safe installation of 5335D or 5337D the following must be observed. The module shall only be installed by qualified personnel who are familiar with the national and international laws, directives and standards that apply to this area. Year of manufacture can be taken from the first two digits in the serial number.

Certificate	IECEX DEK 20.0063X
Marking	Ex ia IIC T6...T4 Ga Ex ia IIIC Db Ex ia I Ma
Standards	IEC 60079-0: 2017, IEC 60079-11: 2011

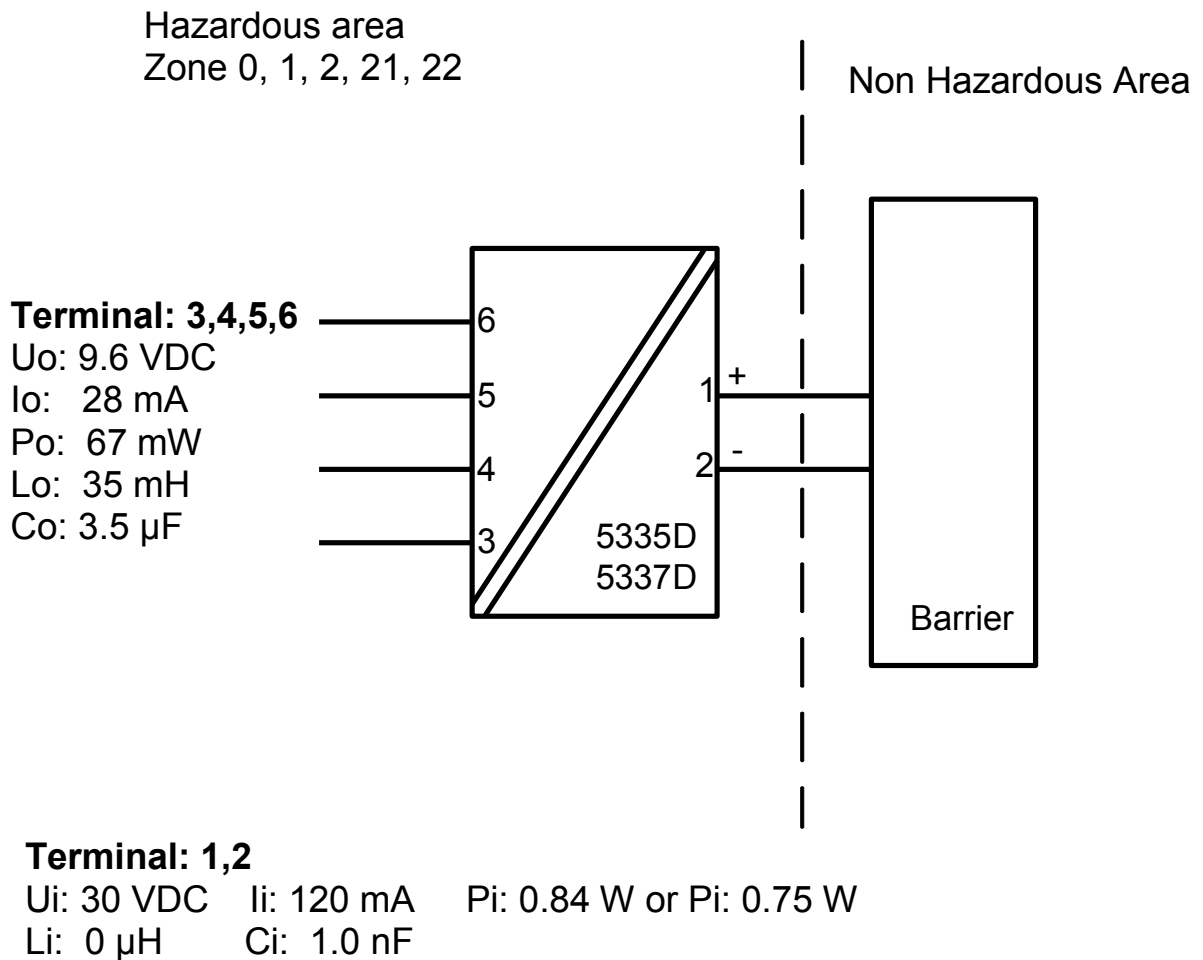

Temperature Class	Ambient temperature range	
	Pi: 0.84 W	Pi: 0.75 W
T6	-40°C to +47°C	-40°C to +50°C
T5	-40°C to +62°C	-40°C to +65°C
T4	-40°C to +85°C	-40°C to +85°C

Installation notes

If the enclosure is made of non-metallic plastic materials, electrostatic charges on the transmitter enclosure shall be avoided.

If the transmitter is installed in an explosive atmosphere requiring the use of equipment protection level Ga, the transmitter shall be mounted in an enclosure that provides a degree of protection of at least IP20 according to IEC 60529, and that is suitable for the application and correctly installed.

If the transmitter is installed in an explosive atmosphere requiring the use of equipment protection level Ga or Ma, and if the enclosure is made of aluminum, it must be installed such, that ignition sources due to impact and friction sparks are excluded.

If the transmitter is installed in an explosive atmosphere requiring the use of equipment protection level Db, the transmitter shall be mounted in a separately certified enclosure that provides a degree of protection of at least IP5X according to IEC 60079-0, and that is suitable for the application and correctly installed. The surface temperature of the outer enclosure is +20 K above the ambient temperature, determined without a dust layer.
Ambient temperature range: -40°C to +85°C.

If the transmitter is installed in an explosive atmosphere requiring the use of equipment protection level Ma, the transmitter shall be mounted in an enclosure that provides a degree of protection of at least IP54 according to IEC 60529, and that is suitable for the application and correctly installed.
Ambient temperature range: -40°C to +85°C.

Cable entries and blanking elements shall be used that are suitable for the application and correctly installed.

For an ambient temperature $\geq 60^\circ\text{C}$, heat resistant cables shall be used with a rating of at least 20 K above the ambient temperature.

The sensor circuit is not infallibly galvanically isolated from the input circuit. However, the galvanic isolation between the circuits is capable of withstanding a test voltage of 500 VAC for 1 minute.