

# **KLAY-INSTRUMENTS**

## **PRESSURE AND LEVEL TRANSMITTERS**

### **WARNING**

Read this manual before working with the product. For personal and system safety, and for optimum product performance, make sure you thoroughly understand the contents before installing, using, or maintaining the SERIES 8000 or SERIES 8000-SAN.

### **SERIES 8000-SAN**



### **SERIES 8000**



Manufactured by :

 **KLAY-INSTRUMENTS**  
[www.klay-instruments.com](http://www.klay-instruments.com)

Nijverheidsweg 5  
P.O. Box 13  
Tel: +31-521-591550  
Fax: +31 -521-592046

7991 CZ DWINGELOO  
7990 AA DWINGELOO  
The Netherlands  
E-mail: [info@klay.nl](mailto:info@klay.nl)

## CONTENTS

SECTION	PAGE	SECTION	PAGE		
1	Introduction	2/8	4	Wiring	5/8
1.1	Description Series 8000-SAN	2/8	4.1	Digital Local Indicator	5/8
1.2	Description Series 8000	2/8	4.2	Hazardous area (Ex)	5/8
1.3	Barometric reference	2/8	4.3	Functional Safety – SIL	6/8
2	Dimensional Drawing	3/8	4.4	Traceability year of manufacturing	6/8
2.1	Dimensional Drawing 8000-SAN	3/8	4.5	CE / EMC-rules	6/8
2.2	Dimensional Drawing 8000	3/8	4.6	External Load	6/8
2.3	Installing Weld-on nipple	3/8	5	Precautions and Warnings	7/8
3	Installing Transmitter	4/8		Attachment: EU-Declaration of conformity	
3.1	Installing Transmitter 8000-SAN	4/8			
3.2	Installing Transmitter 8000	4/8			
3.3	Mounting Position	4/8			
3.4	Mounting Position Effect	4/8			
3.5	Calibration	4/8			

### 1 INTRODUCTION

The SERIES 8000 and SERIES 8000-SAN are solid-state pressure and level transmitters based upon a bridge resistive silicon sensor, with a very high burst pressure. The sensor element is mounted in a stainless steel foot. A strong stainless steel "flush" diaphragm protects the sensor from the process medium. Special oil fills the chamber surrounding the sensor and transfers pressure from the flush mounted diaphragm to the sensor.

Pressure on the sensor element creates a very small deflection of the silicon substrate and bridge network. The resulting strain in the silicon resistors causes a change in the bridge resistance that is proportional to the pressure applied. The transmitter electronics detects this change in bridge resistance and converts it into 4-20 mA. The amplifier system is based on a single Integrated Circuit, which ensures a perfect linearity in the 4-20 mA output. The electronics are fully encapsulated and are there for unaffected by vibrations and moisture.

The Series 8000 and 8000-SAN are available as SIL2, proven in use (Option G200).

#### 1.1 DESCRIPTION SERIES 8000-SAN

The SERIES 8000-SAN are specially designed with a flush mounted diaphragm so they fully meet the needs of the food, pharma and chemical industries. The Series 8000-SAN is available as 3-A version (Sanitary Standard - Option G153) and EHEDG (Sanitary standard – Option G150). Standard wetted parts are made of SS 316, other materials are available, like Hastelloy C. Various process connections can be delivered, such as Tri-Clamp (1.5", 2" and 3"), SMS (1.5" and 2"), dairy milk couplings (DN 25, 40 and 50), flanges (DIN and ANSI) and sanitary weld-on nipples (ø 48, 62 and 85 mm.)

#### 1.2 DESCRIPTION SERIES 8000

The SERIES 8000 are specially designed for the pulp- and paper or similar industries, where clogging is a problem. The very compact construction of the SERIES 8000 permits flush installation with the tank- or pipe wall. Standard wetted parts are made of SS 316, a lot of other materials like Hastelloy C are available as an option.

All transmitters are fully temperature compensated, which means that various process temperatures have nearly no effect on the accuracy of the output signal. When a failure occurs, the transmitter is repairable. However, for optimum accuracy the transmitter has to be sent back to the factory.

#### 1.3 BAROMETRIC REFERENCE

The series 8000 is in basic a so-called "relative transmitter" which means that barometric changes will not affect the zero (4 mA). The venting is placed in the cover of the electronic housing and is the barometric reference to atmospheric pressure. The venting must be kept clean.

**2.1 DIMENSIONAL DRAWING 8000-SAN: PARTS DESCRIPTION:**

**MATERIAL:**

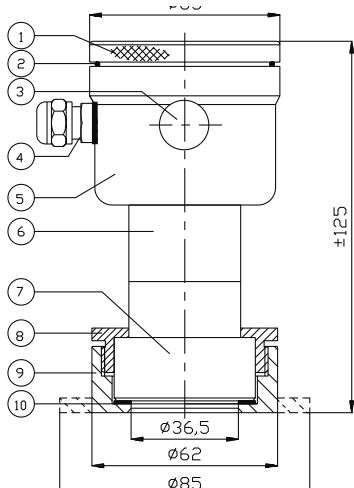

- |                       |          |
|-----------------------|----------|
| 1. Cover              | SS 304   |
| 2. O-ring             | EPDM     |
| 3. Venting            |          |
| 4. PG9 Cable Gland    |          |
| 5. Electronic Housing | SS 304   |
| 6. Foot               | SS 304   |
| 7. Diaphragm and ring | SS 316   |
| 8. Lock ring          | SS 304   |
| 9. Weld-on nipple     | SS 316 L |
| 10. Packing           | PTFE     |

**2.2 DIMENSIONAL DRAWING 8000:**

**PARTS DESCRIPTION:**

**MATERIAL:**

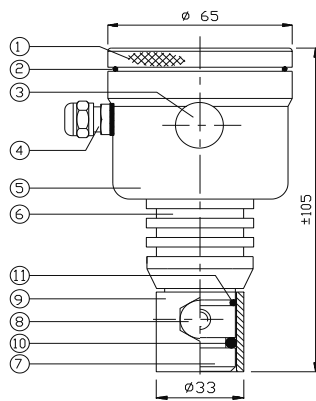

- |                       |          |
|-----------------------|----------|
| 1. Cover              | SS 304   |
| 2. O-ring             | EPDM     |
| 3. Venting            |          |
| 4. PG9 Cable Gland    |          |
| 5. Electronic Housing | SS 304   |
| 6. Cooling fins       | SS 304   |
| 7. Diaphragm and ring | SS 316   |
| 8. M8 Bolt            | SS 304   |
| 9. Weld-on nipple     | SS 316 L |
| 10. O-ring            | VITON    |
| 11. O-ring            | VITON    |

**2.3 INSTALLING WELD-ON NIPPLE:**

The diaphragm of the transmitter is protected with a special protection cap. Protect the diaphragm until installation takes place. **Do not damage the diaphragm.**

A certified welder should perform the installation of the weld-on nipple. Weld with Argon, MIG or TIG, with the smallest welding pin possible.

1. Cut a hole in the process vessel or pipe for a precise fit of the weld-on nipple. The hole should be a tight fit when coupled with the weld-on nipple.
2. Prepare the vessel hole by bevelling the edge to accept filler material.
3. Remove the weld-on nipple from the transmitter.
4. Remove the gasket and O-ring of the weld-on nipple!

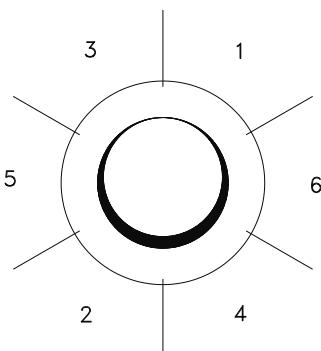

**WARNING:**

Improper installation may result in distortion of the weld-on nipple. Excessive heat will distort the weld-on nipple. Weld in sections as shown in the figure left. Allow adequate cooling between passes. **To reduce the chances of distortion to the weld-on nipple, use a mandrel.**

(SERIES 8000-SAN Part.no. 1019)

(SERIES 8000 Part.no. 1016)

Determine (before welding) the position of the electronic housing, so that the cable entry and the venting are in the right position. After welding these positions are fixed.

5. Position the weld-on nipple in the vessel hole and tack six places. The weld sequence is shown in the figure above.
6. Weld the weld-on nipple in place using 0.03 to 0.045 in. (0.762 to 1.143 mm) stainless rod as filler material in the bevelled area. Adjust amperage for penetration.
7. Remove mandrel after the welding operation.

### **3 INSTALLING TRANSMITTER:**

#### **3.1 INSTALLING TRANSMITTER SERIES 8000-SAN:**

1. Make sure to correctly locate the packing within the weld-on nipple.
2. Improper installation of the packing can cause a process leak.
3. Position the transmitter into the weld-on nipple and begin engaging threads. The transmitter can be rotated prior to seating enabling the user to optimize access to calibration adjustments, cable entry, and local indicator.
4. Once the lockring (8) has been hand tightened, it must be tightened with an additional turn ( $\pm 1/8$ " with adjustable pliers.

#### **3.2 INSTALLING TRANSMITTER SERIES 8000 code W:**

1. After welding, clean up edges, and take care of the inside nipple wall.
2. Make sure the O-rings (10) and (11) are properly located. Improper installation at the O-ring can cause a process leak.
3. Apply silicone grease to the O-ring(10), diaphragm ring and the hole inside wall of the weld-on nipple, this prevents galvanic cell corrosion between transmitter and nipple inside.
4. Install the transmitter and fix it with the SS M8 bolt.

#### **3.3 MOUNTING POSITION:**

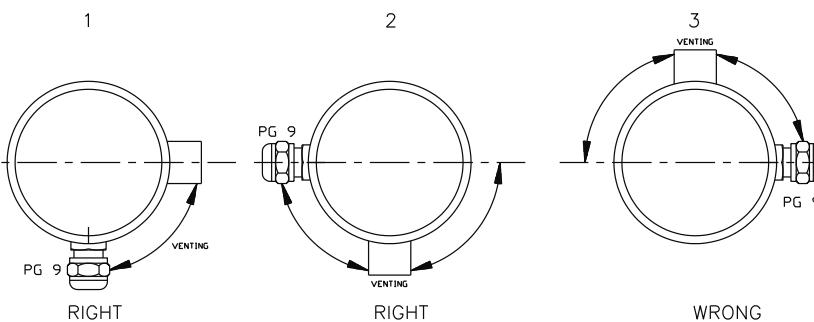

When the transmitter is mounted horizontal, the venting **MUST** be pointed horizontal to downwards. See figure left.

1 = Right (= Preferred Position)  
2 = Right

All other mounting positions are **NOT** allowed (3 = Wrong).

#### **3.4 MOUNTING POSITION EFFECT:**

The transmitters are calibrated in horizontal position.

If the transmitter is mounted vertical (up or down), there will be a zero shift.

If the transmitter is mounted up there is a small zero shift (< 4 mA).

If the transmitter is mounted down there is a small zero shift (> 4 mA).

After installation of the transmitter the zero must be set at 4 mA with the zero potentiometer.

**DO NOT change the span.**

#### **3.5 CALIBRATION:**

All transmitters are fully calibrated at the factory, to the conditions stipulated in users order. When the buyer has not requested calibration, the transmitter will be calibrated at the lowest span.

It may be advisable to recalibrate the transmitter after shipment.

The calibration sequence is as follows:

1. The output of the transmitter must be set at 4 mA (Zero-potentiometer).
2. Air pressure in accordance with the process pressure must be put on the test nipple.
3. The output of the transmitter must be set at 20 mA (Span-potentiometer).
4. Remove the air pressure.
5. Check if the output of the transmitter is 4 mA. (Otherwise repeat steps 1 till 4)
6. Install transmitter (See above).
7. The output must be set at 4 mA (dependable of mounting position).

#### 4 WIRING:

The connector, and zero / span potentiometers are under the cover. Test nipples for calibration of the SERIES 8000 and SERIES 8000-SAN are available on request.

External loads must be placed in the negative side of the 2-wire loop.

The figure left shows the wiring connection of the transmitter. The 2-wires must be connected to connectors 3 (-) and 4 (+) of the terminal board.

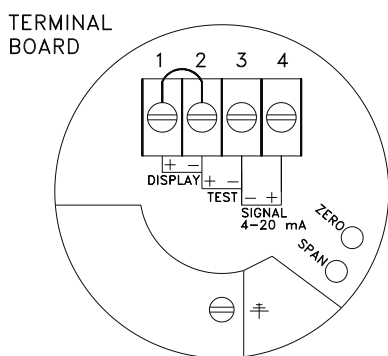
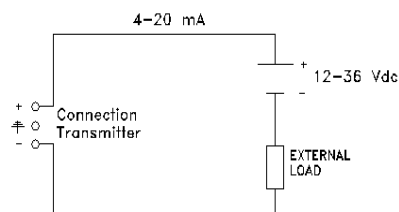

#### **The transmitter must always be connected to earth.**

The transmitter must be connected with standard two-wire shielded cable. **DO NOT** run signal wiring in open trays with power wiring, or near "heavy" electrical equipment (E.g. Frequency controllers or heavy pumps).

Shielding must always be connected at the side of the power supply. In case the mounting position is already connected to ground (e.g. via the tank or pipe line) do NOT connect the instrument to ground. **Please ensure that the instrument is not connected to ground twice to prevent the occurrence of an 'earth loop'.**

Reversing the polarity will not damage the transmitter, but the transmitter will not function until the + and – are properly connected.

#### 4.1 DIGITAL LOCAL INDICATOR:

The local indicator displays a digital value that is proportional to the pressure measured by the transmitter. The full scale point may be set to any value between 0000 and 1999. The local indicator can be mounted afterwards. Remove the bridge which is placed between connector (1) and (2). Connect the red (+) wire to (1) and the black (-) wire to (2). When using a local indicator the minimum power supply must be **15.5 Vdc**.

#### 4.2 HAZARDOUS AREA:

The SERIES 8000 and SERIES 8000-SAN are certified for applications in hazardous areas. When the transmitter is used in such areas, use a certified power supply, from 13 – 26,5 Vdc. Installation of this device has to be carried out by a certified and qualified mechanic or a certified and qualified installer.

### CERTIFICATIONS

#### **ATEX - II 1 G Ex ia IIC T4 Ga**

Certificate : KEMA 03ATEX1219 X

$U_i = 26,5 \text{ Vdc}$ ,  $I_i = 110 \text{ mA}$ ,  $C_i = 1 \text{ nF}$ ,  $L_i = 1.2 \text{ mH}$ ,  $P_i = 0,9 \text{ W}$

$-30^\circ \text{ C} < T_{\text{amb}} < 70^\circ \text{ C}$

The X in the certificate number refers to a special condition only applicable for our submersible level transmitter "HYDROBAR" –cable and –FR. See for this conditions the ATEX-certificate.

The maximum length of the cable for the Series-8000-cable, Series-8000-SAN-cable and Hydrobar-cable is 32 m. Electrostatic charging of the cable and the protection cap by the flow of non-conductive media (e.g. in stirring vessels or pipes) shall be avoided.

#### **IECEX - Ex ia IIC T4 Ga**

Certificate: DEK 13.0060X

$U_i = 26.5 \text{ Vdc}$ ,  $I_i = 110 \text{ mA}$ ,  $C_i = 1 \text{ nF}$ ,  $L_i = 1.2 \text{ mH}$ ,  $P_i = 0.9 \text{ W}$

$-30^\circ \text{ C} < T_{\text{amb}} < 70^\circ \text{ C}$

*All certifications are in compliance with IECEx scheme rules, and the International Standards :*

*IEC 60079-0:2011, IEC 60079-11:2011, IEC 60079-26:2007 and IEC 17050-1. They are certified for use in hazardous areas by DEKRA B.V.*



**DO NOT REMOVE THE SCREW COVER(S) WHEN AN EXPLOSIVE ATMOSPHERE MAY BE PRESENT.**

#### **4.3 FUNCTIONAL SAFETY - SIL**

The device is certified as "Proven in use" for a Functional safety environment of SIL2 according to IEC-61511 and SIL2 according to IEC-61508.

Note 1 : According to IEC 61511, 11.4.4 SIL3 is possible in 1oo2 configuration (two-channel redundant architecture)

Note 2: Option SIL (Proven in use) is valid on transmitters with a serial number > 10509426

When ordered as a SIL (Proven in use) transmitter, the safety manual will be supplied. (Option G200)  
Detailed information can be found in the Safety manual of the instrument. The most recent version of the Safety manual is available on: <http://www.klay-instruments.com> under section "Downloads".

#### **4.4 TRACEABILITY YEAR OF MANUFACTURING:**

The year of manufacturing of the transmitter can be traced as follows: take the first two numbers from the serial number that is engraved in the transmitter and add 1908.

For example: if the serial number is 10509426. The year of manufacturing is 1908 + 105 = 2013.

For older transmitters, for example with serial number 9302123, the first **two** numbers must be add to 1908.

#### **4.5 CE / EMC - Rules:**

All Klay transmitters are manufactured in accordance with the RFI / EMC directives and comply with the CE standard. All transmitters are fitted with RFI filters, which provide optimum, trouble-free operation. Our products are in conformity with EMC-Directive 2004/108/EC based on test results using harmonized standards.

#### **4.5 EXTERNAL LOAD:**

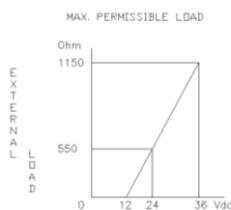

The maximum permissible load (Ri max.) in case of 24 Vdc is 550 Ω (Ohm).

By increasing the power supply, the external load can be increased to 1150 Ohm / 36 Vdc. (see figure left).

$$Ri \text{ max.} = \frac{\text{Power Supply} - 13 \text{ Vdc (min. power supply)}}{20 \text{ mA}}$$

**SPECIFICATIONS**

<i>Manufacturer</i>	Klay Instruments B.V.
<i>Instrument</i>	Series 8000 Series 8000-SAN
<i>Output</i>	4-20 mA
<i>Power Supply</i>	12 - 36 Vdc Ex-version: 13 - 26,5 Vdc
<i>Accuracy</i>	0,2% of adjusted span
<i>Process temperature</i> <sup>1</sup> Series 8000 Series 8000-SAN Series 8000-Cable Series 8000-SAN-Cable	-20°C to + 80° C (-4 °F to 176 °F) -20°C to +100°C (-4 °F to 212 °F) -20°C to + 80°C (-4 °F to 176 °F) -20°C to + 80°C (-4 °F to 176 °F)
<i>Temperature effect</i>	0,015% / K
<i>Ambient Temperature</i>	-20°C to +70C (-4 °F to 158 °F) For Ex-version see paragraph 4.2
<i>Protection grade</i>	IP 66 IP 68 (for 8000-cable and 8000-SAN-Cable submersed parts)
<i>Material</i> <i>Housing</i> <i>"wetted" part</i>	AISI 304 AISI 316 L

<sup>1</sup> For higher process temperatures please use Series 8000-SAN with option HT and specify the exact process temperature, or contact Klay Instruments.

## 6.

## PRECAUTIONS and WARNINGS:

- \* **Check if the specifications of the transmitter meet the needs of the process conditions.**
  - \* **When the SERIES 8000 or 8000-SAN is used as a level transmitter, be aware of the place where the transmitter is mounted. Here are some advises:**
    1. **DO NOT** mount a level transmitter in- or near filling or discharging pipes.
    2. **In case of automatic cleaning systems or hand cleaning: never point the water jets on the diaphragm, take necessary steps to avoid this. Guarantee will not be granted.**
  - \* **When the SERIE 8000 or SERIES 8000-SAN is used as a pressure transmitter, be aware of the following points:**
    1. **Rapid closing valves in combination with high flow velocity will cause water hammer(spikes) and can destroy the transmitter. DO NOT** mount a transmitter near such valves, always a few pipe bends away up or down stream (avoid suction).
    2. **Install a pressure transmitter a few pipe bends away from pumps, as well on the suction or pressure side of the pump.**
  - \* **WELDING ADVISEMENT:**  
**When using the SERIES 8000 or 8000-SAN code "W" the welding advisements on page 3 must be followed exactly. This is very important to prevent distortion of the weld-on nipples. It also prevents the screw thread from the SERIES 8000-SAN (M56 x 1,25) from being deformed.**
  - \* **The diaphragm of the transmitter is protected with a special protection cap. Protect the diaphragm until installation takes place, to prevent damaging of the diaphragm.**
  - \* **As soon as the wiring is brought inside through the PG9 cable gland and connected to the terminal board, make sure the cable gland is tightly fixed, so that moisture cannot enter into the electronic housing.**
  - \* **NEVER unscrew the venting (3), because it is especially designed to prevent moisture from entering into the electronic housing. If the ambient conditions are very wet, we advise to use a venting through the cable. A special vented cable can be delivered on request.**
  - \* **Avoid high pressure water-jets pointed at the venting.**
  - \* **The cover must be fully engaged, so that moisture cannot ingress into the electronic housing. The cover must only be capable of being released or removed with the aid of a tool.**
  - \* **WARRANTY: The warranty is 1 year from delivery date. Klay Instruments B.V. does not accept liability for consequential damage of any kind due to use or misuse of the SERIES 8000 or SERIES 8000-SAN. Warranty will be given, to be decided by the manufacturer. Transmitter must be shipped prepaid to the factory on manufacturer's authorization.**
- NOTE: Klay Instruments B.V. reserves the right to change its specifications at any time, without notice. Klay Instruments B.V. is not an expert in the customer's process (technical field) and therefore does not warrant the suitability of its product for the application selected by the customer.**

Manufactured by:

 **KLAY-INSTRUMENTS B.V.**

[www.klay-instruments.com](http://www.klay-instruments.com)

Nijverheidsweg 5  
P.O. Box 13  
Tel: +31-521-591550  
Fax: +31 -521-592046

7991 CZ DWINGELOO  
7990 AA DWINGELOO  
The Netherlands  
E-mail: [info@klay.nl](mailto:info@klay.nl)



# EU-DECLARATION OF CONFORMITY

## Klay Instruments B.V.

Nijverheidsweg 5, 7991 CZ Dwingeloo, The Netherlands

Certify that the equipment intended for use in potentially explosive atmospheres, only new products, indicated here after:

Electronic Pressure- and Level Transmitters  
Series 8000-SAN, Series 8000, Series CER-8000  
Hydrobar-Cable, Hydrobar-EXTD, Hydrobar-FR

Are in accordance with:

- Directive 2014/34/EU (Equipment and protective systems for use in potentially explosive atmospheres)
- Directive 2014/30/EU (Electro Magnetic Compatibility).
- Harmonized standards:
  - EN 60079-0:2012 (General rules)  
*This standard has been compared with EN 60079-0:2018 (Currently Harmonised) and no significant changes have occurred which are applicable to this equipment.*
  - EN 60079-11:2012 (Intrinsic safety "i")
  - EN 60079-26:2007 (Group II cat. 1G requirements)  
*This standard has been compared with EN 60079-26:2015 (Currently Harmonised) and no significant changes have occurred which are applicable to this equipment.*
  - IEC 61000-6-2: 2001 (EMC, Immunity in industrial location)
  - IEC 61000-6-3: 2001 (EMC, Emission in industrial location)
  - IEC 61000-6-4: 2001 (EMC, Emission in industrial location)
  - EN-ISO-IEC 80079-34:2011 (Potentially explosive atmospheres – Application of quality systems)

- The type (protection mode "ia") which has been the subject of;

**EC-type Examination Certificate Numbers:**

KEMA 03 ATEX1219 X, Issue 5

Delivered by the KEMA, Meander 1051, 6825 MJ Arnhem, The Netherlands, Notified Body No. 0344.

Manufacturing plant in Dwingeloo which has been the subject of;

**Production Quality Assurance Notification Number:**

DEKRA 12ATEXQ0041, Issue 3

Delivered by the DEKRA, Meander 1051, 6825 MJ Arnhem, The Netherlands, Notified Body No. 0344.

Date: October 1<sup>st</sup>, 2019

Signature:

E. Timmer  
Managing Director - Klay Instruments B.V.

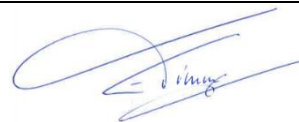

The marking of the equipment is as follows:

**II 1G Ex ia IIC T4 Ga**

- II means that the equipment has been built for use in surface industries (and not in mines endangered by firedamp).
- 1 equipment for use in Zone 0 (if G)
- G equipment for use with gas, vapours or mists
- Ex equipment in compliance with European standards for explosive atmospheres
- ia equipment in compliance with specific building rules for intrinsically safe equipment
- IIC equipment for use with gas of subdivision C
- T4 equipment whose surface temperature does not exceed 135°C with < 70°C Ambient temperature.

Protection Grade, Series 8000-SAN, 8000, CER-8000, **IP 66**

Protection Grade, Series Hydrobar-cable, Hydrobar-EXTD, **IP 66**

**The Hydrobar-FR and all other submersible parts from the Series Hydrobar are IP 68.**

Furthermore, whatever the protection mode, only use cable glands with a protection degree of at least IP 66.

Be sure the cable diameter complies with the selected cable gland. Tighten the cable gland in a proper way.

Never forget to mount the covers of the electronics housings in a proper way.

**For other technical details, refer to the instruction manuals of the series transmitters.**



Nijverheidsweg 5  
P.O. Box 13

7991 CZ Dwingeloo  
7991 AA Dwingeloo

Tel.: +31 521 591550  
Fax.: +31 521 592046

The Netherlands  
e-mail: info@klay.nl