

KLAY-INSTRUMENTS

INSTRUCTION MANUAL PERAMIC

WARNING:

Before installing the "PERAMIC", read the warnings and advisements on page 4. For personal and system safety, and for optimum performance, make sure you thoroughly understand the contents before installing..

DESCRIPTION:

The PERAMIC is a solid state, *All Stainless*, pressure transmitter based on a ceramic pressure cell with a very high burst pressure. The amplifier system is based on a single Integrated Circuit, which ensures a perfect linearity in the 4-20 mA output. Also the transmitter is fully temperature compensated. The PERAMIC is made for pressure applications on liquids, gases and vapours. Zero and Span are internally adjustable in wide ranges. A local digital indicator is available (option).



OPERATION PERAMIC:

The PERAMIC has no oil filling system, so the process pressure goes directly to the ceramic pressure cell. The voltage signal from the ceramic cell goes directly to the Integrated Circuit that converts this signal into 4-20 mA. Therefore the PERAMIC has a perfect linearity. The PERAMIC is fully temperature compensated, which means that various process temperatures have no effect on the accuracy of the output signal.

DIMENSIONS PERAMIC (1/2" BSP acc. to DIN 16288):

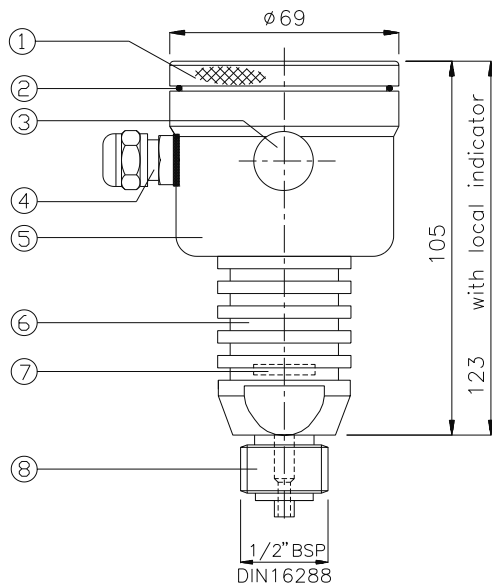

PARTS DESCRIPTION:

- | | |
|------------------------------------|---------|
| 1. Cover | SS 304 |
| 2. O-ring | EPDM |
| 3. Venting | PA |
| 4. PG9 Cable Gland | PA |
| 5. Electronics Housing | SS 304 |
| 6. Foot | SS 316 |
| 7. Sensor (pressure cell) | Ceramic |
| 8. Process connection 1/2" BSP (m) | SS 316 |
- acc. to DIN 16288

MATERIAL:

Note: The Sensor is sealed with an O-ring (VITON). Other materials can be delivered on request.

BAROMETRIC REFERENCE:

The PERAMIC is in basic a so called "relative transmitter" which means that barometric changes will not affect the zero (4 mA). The venting nipple (3) is placed at the side of the electronic housing and is the barometric reference to atmospheric. The venting nipple must be kept clean.

PERAMIC-ENG

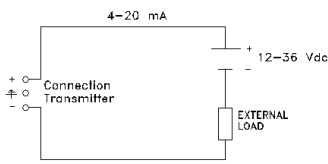

WIRING:

The figure left shows the wiring connection of the PERAMIC. The 2-wires must be connected to connectors 3(-) and 4 (+). In most circumstances the load should be placed in the negative leg of the 2-wire loop, although it is not necessary.

TEST FUNCTION:

Without braking into the loop you can measure the actual output (mA) of the transmitter by means of connecting a multimeter to the connectors 2(+) and 3(-) in the mA mode.

TERMINAL BOARD

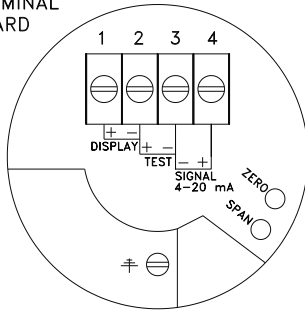

WIRING:

The transmitter must always be connected to earth. The transmitter must be connected with standard two-wire shielded cable. **DO NOT** run signal wiring in open trays with power wiring, or near heavy" electrical equipment (E.g. frequency controllers or heavy pumps). Shielding must always be connected at the side of the power supply. In case the mounting position is already connected to ground (e.g. by tank or pipe line) do NOT connect the instrument to earth. **Please ensure that the instrument is not connected to ground twice to prevent the occurrence of an 'earth loop'**. In application with synthetic mounting positions the enclosure grounding (internal or external) must be connected to ground. Note: The Peramic-type with a synthetic process connection *must* be connected to ground.

Reversing the polarity will not damage the transmitter, but the transmitter will not function until the + and – are properly connected.

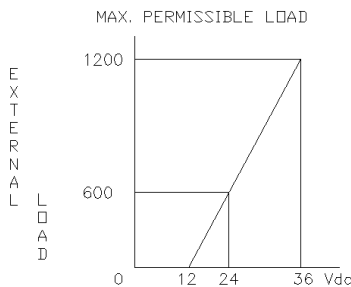

POWER SUPPLY / EXTERNAL LOAD:

The minimum power supply is based on the total circuit resistance. The maximum permissible load (Ri max.) in case of 24 Vdc will be 600 Ohm. By increasing the power supply, the external load can be higher, till 1200 Ohm / 36 Vdc. (see figure left).

$$Ri \text{ max.} = \frac{\text{Power Supply} - 13 \text{ Vdc (min. Power supply)}}{20 \text{ mA.}}$$

CALIBRATION:

All transmitters are fully calibrated at the factory, to the conditions stipulated in users order. When the buyer has not requested calibration, the transmitter will be calibrated at the lowest span. It may be advise able to recalibrate the transmitter after shipment.

The calibration sequence is as follows:

1. The output of the transmitter must be set at 4 mA (Zero-potentiometer).
2. Air pressure in accordance with the process pressure must be put on the test nipple.
3. The output of the transmitter must be set at 20 mA (Span-potentiometer).
4. Remove the air pressure.
5. Check if the output of the transmitter is 4 mA. (Otherwise repeat steps 1 till 4)
6. Install transmitter (See above).
7. The output must be set at 4 mA (dependable of mounting position).

COMPOUND RANGE (combination overpressure and underpressure measurement):

For example: if the transmitter is adjusted at –100...+100 mbar the output of the transmitter at atmospheric pressure must be 12 mA. If not this must be set at 12 mA by means of turning the ZERO potentiometer. After this a test pressure of 100 mbar should be put on the transmitter and the output should show 20 mA. If not this must be set at 20 mA by means of turning the SPAN potentiometer. When the test pressure is removed the transmitter should show 12 mA at atmospheric pressure. If not the above sequence should be repeated.

INSTALLATION:

When mounting the "PERAMIC", use the same principles as those for a manometer (gauge). We recommend using shut-off valves and water trap pipes acc. to BS/DIN standards, especially on steam applications and those applications where the process temperature will be higher than 100°C.

DIGITAL LOCAL INDICATOR:

The local indicator displays a digital value that is proportional to the pressure measured by the transmitter. The full scale point may be set to any value between 0000 and 1999. The local indicator can be mounted afterwards. Remove the bridge which is placed between connector (1) and (2). Connect the red (+) wire to (1) and the black (-) wire to (2). When using a local indicator the minimum power supply must be **15,5 Vdc**.

HAZARDOUS AREA:

The PERAMIC is certified for applications in hazardous areas.

Certification: II 1G Ex ia IIC T4 Ga (intrinsically safe). When the PERAMIC is used in such areas, use a certified power supply, from 13 - 26,5 Vdc. Installation of this device has to be carried out by a certified and qualified mechanic or a certified and qualified installer.

CERTIFICATIONS

ATEX - II 1 G Ex ia IIC T4 Ga

Certificate : KEMA 03ATEX1219 X

$U_i = 26,5 \text{ Vdc}$, $I_i = 110 \text{ mA}$, $C_i = 1 \text{ nF}$, $L_i = 1.2 \text{ mH}$, $P_i = 0,9 \text{ W}$

$-30^\circ \text{ C} < T_{\text{amb}} < 70^\circ \text{ C}$

The X in the certificate number refers to a special condition only applicable for our submersible level transmitter "HYDROBAR" –cable and –FR. See for this conditions the ATEX-certificate.

IECEX - Ex ia IIC T4 Ga

Certificate: DEK 13.0060X

$U_i = 26.5 \text{ Vdc}$, $I_i = 110 \text{ mA}$, $C_i = 1 \text{ nF}$, $L_i = 1.2 \text{ mH}$, $P_i = 0.9 \text{ W}$

$-30^\circ \text{ C} < T_{\text{amb}} < 70^\circ \text{ C}$

All certifications are in compliance with IECEx scheme rules, and the International Standards : IEC 60079-0:2011, IEC 60079-11:2011, IEC 60079-26:2007 and IEC 17050-1. They are certified for use in hazardous areas by DEKRA B.V.



DO NOT REMOVE THE SCREW COVER(S) WHEN AN EXPLOSIVE ATMOSPHERE MAY BE PRESENT.

FUNCTIONAL SAFETY - SIL

The device is certified as "Proven in use" for a Functional safety environment of SIL2 according to IEC-61511 and SIL2 according to IEC-61508.

Note 1 : According to IEC 61511, 11.4.4 SIL3 is possible in 1oo2 configuration (two-channel redundant architecture)

Note 2: Option SIL (Proven in use) is valid on transmitters with a serial number > 10509426

When ordered as a SIL (Proven in use) transmitter, the safety manual will be supplied. (Option G200)
Detailed information can be found in the Safety manual of the instrument. The most recent version of the Safety manual is available on: <http://www.klay-instruments.com> under section "Downloads".

TRACEABILITY YEAR OF MANUFACTURING:

The year of manufacturing of the transmitter can be traced as follows: take the first two numbers from the serial number that is engraved in the transmitter and add 1908.

For example: if the serial number is 10509426. The year of manufacturing is $1908 + 105 = 2013$.

For older transmitters, for example with serial number 9302123, the first **two** numbers must be add to 1908.

PROCESS TEMPERATURE

-20° C to $+80^\circ \text{ C}$ (Temperature effect 0,015% / K)

ADVISEMENTS and WARNINGS:

We herewith give a list of some advisements and warnings concerning the application and installation of the electronic pressure transmitter, the "PERAMIC":

- * Check if the specifications of the PERAMIC meet the needs of the process conditions.
- * The Ceramic Sensor in combination with the VITON O-ring can withstand nearly all process fluids, gases and vapours. However, always check if ceramic and VITON can be applied. Other O-ring materials are available on request.
- * When the PERAMIC is mounted horizontal, be aware that the venting must be pointed downwards of the electronic housing, all other mounting positions are NOT allowed.
- * When a flush diaphragm has to be used, for food- or paper industry, ask for our transmitters series 8000 or 8000-SAN.
- * When the PERAMIC is used as a pressure transmitter, be aware of the following points:
 1. Rapid closing valves in combination with high flow velocity will cause water hammer(spikes) and can destroy the transmitter. DO NOT mount the PERAMIC near such valves, always a few pipe bends away up or down stream (avoid surching).
 2. Place a pressure transmitter a few pipe bends away from pumps, as well on the suction or pressure side of the pump.
- * When the PERAMIC is used as a level transmitter, be aware of the place where the transmitter is mounted. Here are some advises:
 1. DO NOT mount a level transmitter in- or near filling or discharging pipes.
 2. In case of automatic cleaning systems or hand cleaning: never point the water jets on the diaphragm, take necessary steps to avoid this. Guarantee will not be granted.
- * As soon as the wiring is brought inside through the PG9 cable gland and connected to the terminal board, make sure the cable gland is tightly fixed, so that moisture cannot enter into the electronic housing.
- * NEVER unscrew the venting(3), because it is especially designed to prevent moisture from entering into the electronic housing. If the ambient conditions are very wet, we advise to use a venting through the cable. A special vented cable can be delivered on request.
- * Avoid high pressure water-jets pointed at the venting.
- * The cover must be fully engaged, so that moisture cannot ingress into the electronic housing. The cover must only be capable of being released or removed with the aid of a tool.
- * **WARRANTY:** The warranty is 1 year after delivery.
Klay Instruments B.V. does not accept liability for consequential damage of any kind due to use or miss use of the PERAMIC. Warranty will be given, to be decided by the manufacturer. Transmitter must be shipped prepaid to the factory on manufacturer's authorization.
- * **NOTE:** Klay Instruments B.V. reserves the right to change its specifications at any time, without notice. Klay Instruments B.V. is not an expert in the customer's process (technical field) and therefore does not warrant the suitability of its product for the application selected by the customer.

Manufactured by:

 **KLAY-INSTRUMENTS**
www.klay-instruments.com

Nijverheidsweg 5
P.O. Box 13
Tel: +31-521-591550
Fax: +31-521-592046

7991 CZ DWINGELOO
7990 AA DWINGELOO
The Netherlands
E-mail: info@klay.nl

EU-DECLARATION OF CONFORMITY

Klay Instruments B.V.

Nijverheidsweg 5, 7991 CZ Dwingeloo, The Netherlands

Certify that the equipment intended for use in potentially explosive atmospheres, only new products, indicated here after:

Electronic Pressure- and Level Transmitters
Series 8000-SAN, Series 8000, Series CER-8000
Hydrobar-Cable, Hydrobar-EXTD, Hydrobar-FR

Are in accordance with:

- Directive 2014/34/EU (Equipment and protective systems for use in potentially explosive atmospheres)
- Directive 2014/30/EU (Electro Magnetic Compatibility).
- Harmonized standards:
 - EN 60079-0:2012 (General rules)
This standard has been compared with EN 60079-0:2018 (Currently Harmonised) and no significant changes have occurred which are applicable to this equipment.
 - EN 60079-11:2012 (Intrinsic safety "i")
 - EN 60079-26:2007 (Group II cat. 1G requirements)
This standard has been compared with EN 60079-26:2015 (Currently Harmonised) and no significant changes have occurred which are applicable to this equipment.
 - IEC 61000-6-2: 2001 (EMC, Immunity in industrial location)
 - IEC 61000-6-3: 2001 (EMC, Emission in industrial location)
 - IEC 61000-6-4: 2001 (EMC, Emission in industrial location)
 - EN-ISO-IEC 80079-34:2011 (Potentially explosive atmospheres – Application of quality systems)

- The type (protection mode "ia") which has been the subject of;

EC-type Examination Certificate Numbers:

KEMA 03 ATEX1219 X, Issue 5

Delivered by the KEMA, Meander 1051, 6825 MJ Arnhem, The Netherlands, Notified Body No. 0344.

Manufacturing plant in Dwingeloo which has been the subject of;

Production Quality Assurance Notification Number:

DEKRA 12ATEXQ0041, Issue 3

Delivered by the DEKRA, Meander 1051, 6825 MJ Arnhem, The Netherlands, Notified Body No. 0344.

Date: October 1st, 2019

Signature:

E. Timmer
Managing Director - Klay Instruments B.V.

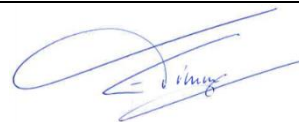

The marking of the equipment is as follows:

II 1G Ex ia IIC T4 Ga

- II means that the equipment has been built for use in surface industries (and not in mines endangered by firedamp).
- 1 equipment for use in Zone 0 (if G)
- G equipment for use with gas, vapours or mists
- Ex equipment in compliance with European standards for explosive atmospheres
- ia equipment in compliance with specific building rules for intrinsically safe equipment
- IIC equipment for use with gas of subdivision C
- T4 equipment whose surface temperature does not exceed 135°C with < 70°C Ambient temperature.

Protection Grade, Series 8000-SAN, 8000, CER-8000, **IP 66**

Protection Grade, Series Hydrobar-cable, Hydrobar-EXTD, **IP 66**

The Hydrobar-FR and all other submersible parts from the Series Hydrobar are IP 68.

Furthermore, whatever the protection mode, only use cable glands with a protection degree of at least IP 66.

Be sure the cable diameter complies with the selected cable gland. Tighten the cable gland in a proper way.

Never forget to mount the covers of the electronics housings in a proper way.

For other technical details, refer to the instruction manuals of the series transmitters.



Nijverheidsweg 5
P.O. Box 13

7991 CZ Dwingeloo
7991 AA Dwingeloo

Tel.: +31 521 591550
Fax.: +31 521 592046

The Netherlands
e-mail: info@klay.nl