

INSTRUCTION MANUAL HydroCER-I

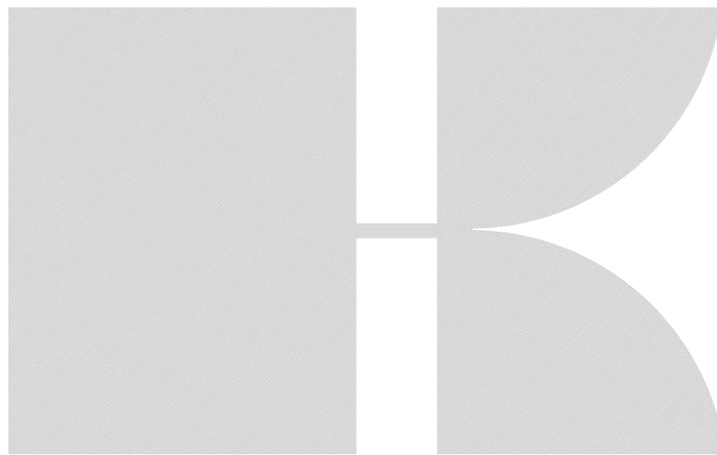

WARNING

Read this manual before working with the product. For personal and system safety and for optimum product performance, make sure you thoroughly understand the contents before installing, using, or maintaining the HydroCER-I. Read the precautions and warnings on the last page.

Manufactured by:

 **KLAY-INSTRUMENTS B.V.**

www.klay.nl

Nijverheidsweg 5
P.O. Box 13
Tel: +31-521-591550
Fax: +31-521-592046

7991 CZ DWINGELOO
7900 AA DWINGELOO
The Netherlands
Email: info@klay.nl

CONTENTS

Chapter		page
1	Introduction	3
1.1	Description Series HydroCER-I	3
1.2	Barometric reference	3
1.3	Wiring HydroCER-I	3
1.4	Calibration	4
1.5	Power supply / External Resistor	4
2	Traceability / Year of Manufacturing	5
3	Parts Description	6
4	Wiring diagram: communication with PC or handheld terminal	7
5	Installation of the software	8/9
6	Conversion Table	10
7	Extra	11
8	Technical specifications	12
9	Warning and Precautions	13

INTRODUCTION

1.1 DESCRIPTION HydroCER-I

The HydroCER-I is an Intelligent hydrostatic level transmitter based upon a capacitive ceramic sensor, with a very high burst pressure. The HydroCER-I can be applied for level measurement, fluids and slurries in tanks, underground storage, reservoirs, monitoring well, pumping well, etc. The compact electronics are placed in a Stainless Steel housing which is fixed to the cable and can be fully submersed (IP68). The HydroCER-I can be installed with a wall mounting bracket (AISI 316) and can be fixed on the requested height by a cable hanger (extra price) Zero and Span are free adjustable with HART® protocol (Hand terminal or PC). With the software the engineering unit and electronic damping can be adjusted.

For further description of the software go to page 7 till 11.

The HydroCER-I is applied with a very strong Ceramic sensor. The compact electronics are mounted in a Stainless steel body, fixed to the cable and can be fully submersed (IP68).

1.2 BAROMETRIC REFERENCE

The HydroCER-I is in basic a so-called Relative transmitter which means that barometric changes will not affect the zero (4 mA). The venting tube in the center of the cable makes the reference to atmospheric pressure. This venting at the end of the cable must be placed in an **absolute dry area** to prevent moisture coming into the transmitter.

A special junction box can be delivered as an option. This junction box has a protection grade of IP 66 and has a special venting nipple. This venting must be kept clean. Dimensions: 80 x 75 x 76. As standard there are two M20 cable glands at one side.

1.3 WIRING (HYDROCER-I)

Black wire = -
 Red wire = +

The transmitter must be connected with standard two-wire shielded cable. Do **NOT** run signal wiring in open trays with power wiring, or near "heavy" electrical equipment (E.g. Frequency controllers or heavy pumps). Shielding must always be connected at the side of the power supply. The instrument always needs to be connected to ground. The transmitters must be connected to earth.

Please ensure that the instrument is not connected to ground twice to prevent the occurrence of an 'earth loop'.

Reversing the polarity will not damage the transmitter, but the transmitter will not function until the + and - are properly connected.

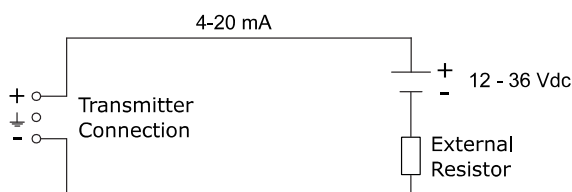

1.4. CALIBRATION

The HydroCER-I transmitters are fully calibrated at the factory, to the specified range of the customer. When the customer has requested a range, the transmitter will be calibrated at the highest span. For calibration with tests pressures, special test nipples are available on request. For calibration software should be used which is included in the delivery. (page 5 till 9)

1.5. POWER SUPPLY / EXTERNAL LOAD

The minimum power supply is based on the total circuit resistance. The maximum permissible load (R_i max.) in case of 24 Vdc will be 600 Ohm. By increasing the power supply, the external load can be higher, till 1400 Ohm / 40 Vdc. (see figure left).

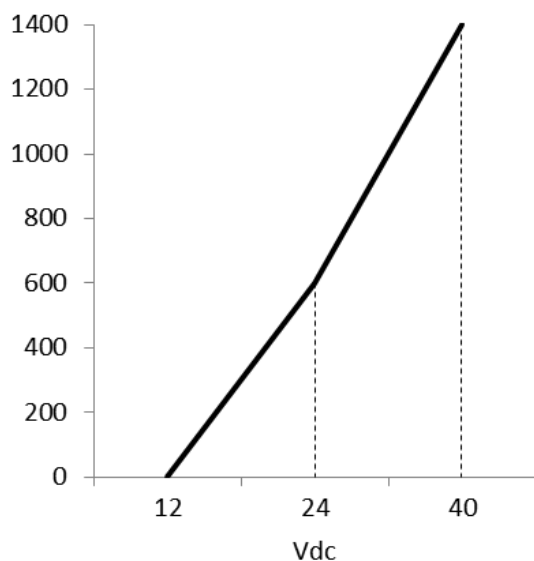

$$R_i \text{ max} = \frac{\text{Power Supply} - 12 \text{ Vdc}}{20 \text{ mA}}$$



With a loop resistance of 250 Ω a power supply of at least 17 Vdc must be used.

2. TRACEABILITY / YEAR OF MANUFACTURING

The year of manufacturing of the transmitter can be traced as follows: The first code (Prefix number) identifies the transmitter as a HydroCER-I (103 = 2011). The 2nd code is the month and the 3rd code is a reference number. For example: 10301001 is a transmitter, produced in 2011 in month January and this was the first produced transmitter in January (Reference number).

INTELLIGENT HYDROSTATIC CABLE LEVEL TRANSMITTER
Type: HydroCER-I-Cable (..m)-range
HART® Protocol Included

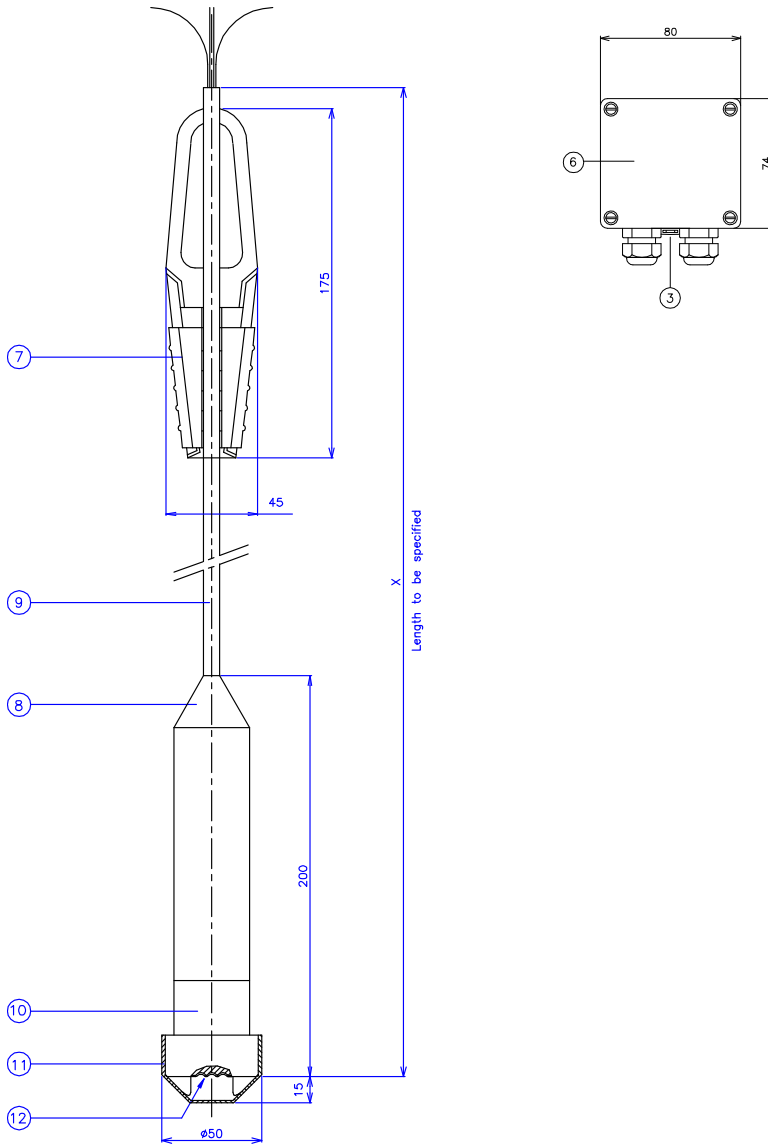

3. DESCRIPTION PARTS

Item	Quantity	Description	Material
3	1	Venting nipple (option, extra price)	PA
6	1	Connection box with venting (option, extra price)	PC
7	1	Cable Hanger (option, extra price)	AISI 304 and PE
8	1	Connection to cable	AISI 316
9	1	Cable with venting tube (diameter 10 mm)	PE
10	1	Foot with sensor	AISI 316
11	1	Diaphragm protection cap	PE
12	1	Diaphragm	AISI 316 L

The cable material (9) is Poly Ethylene (PE) with an outside diameter of 10 mm. As standard the cable length (L) is 3 meters, however every cable length can be delivered on request and has to be specified in the ordering code (extra price above 3 meters). The venting tube at the end of the cable must be placed in an **absolute dry area** to prevent moisture ingress. This is extremely important. For a good venting a junction box (6) with a protection grade of IP 66 can be delivered on request (extra price). This connection box has a special venting nipple (3). A cable hanger (7) to mount the transmitter on every desired length can be delivered (extra price).

4. WIRING DIAGRAM: COMMUNICATION WITH PC

For programming the Series HydroCER-I you must use a HART-modem. Also a minimum resistance of 250 Ohms **must** be present in the loop of the 2-wire system. (See figure below). This is necessary for good communication. If other equipment is part of the 4-20 mA loop (with a resistance of at least 250 Ohm) this is **not** necessary.

⚠ With a loop resistance of 250 Ω a power supply of at least 17 Vdc must be used.

The HydroCER-I can also be programmed with a Hand Held Terminal (HHT) from the HART Foundation or the HHT from Rosemount" (type 275 Hart Communicator). The HART Communicator provides a common communication link to all HART-compatible, instruments. (HART = Highway Addressable Remote Transducer).

Below two connection methods are shown. Other connection methods can possibly limit the function of the HART modem.

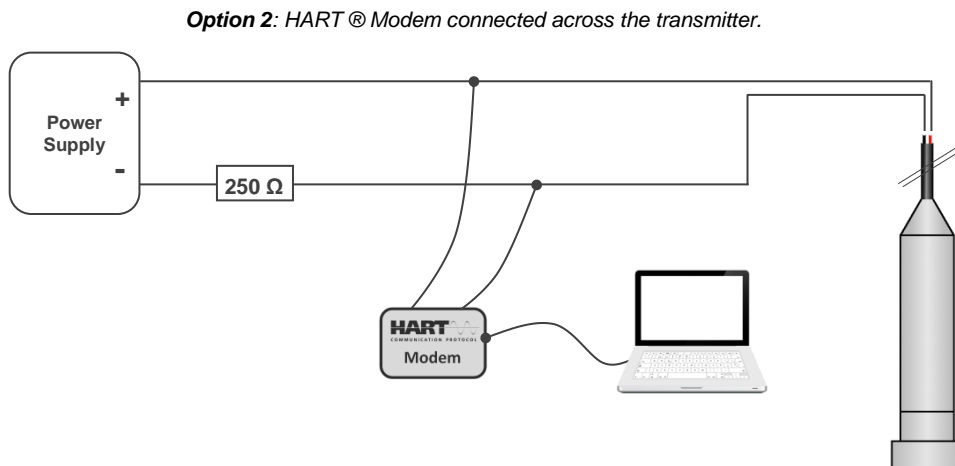
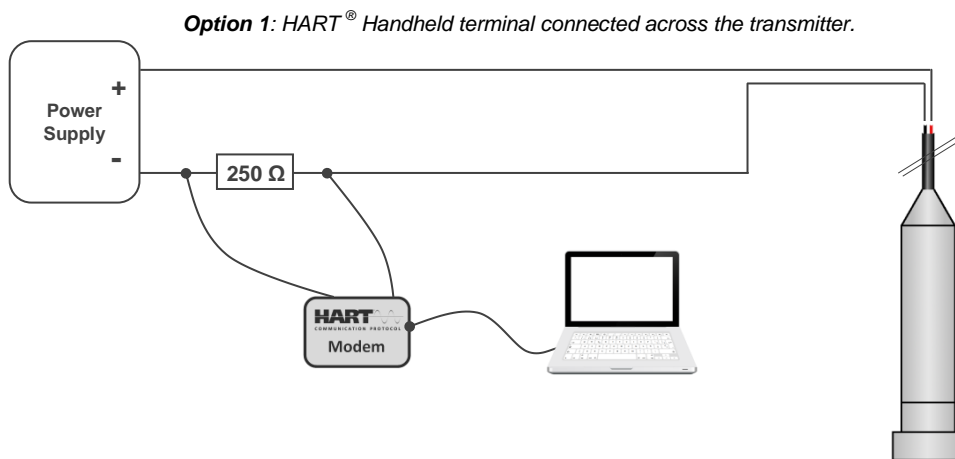

5. INSTALLATION OF THE SOFTWARE (is included in the shipment)

Run the “*setup.exe*” from the CD-ROM or the station where the software is stored. After the setup in the directory programs an additional program called “*HydroCER-I config*” is visible. If you push this button the following window appears:

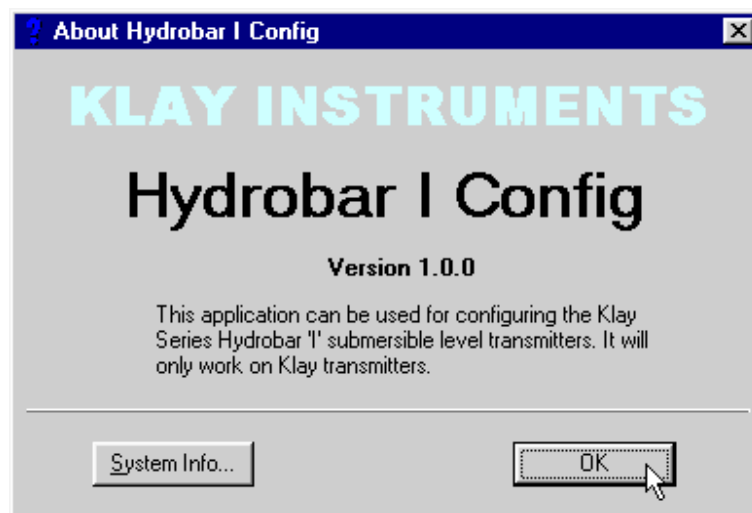

Push “Ok” to get the next window.

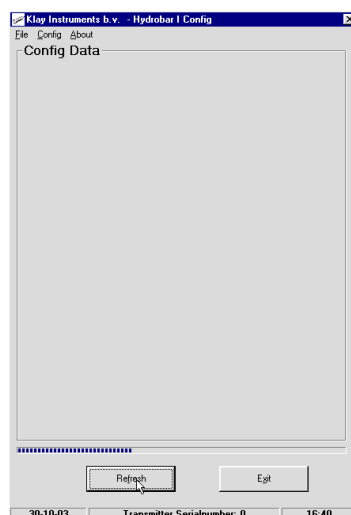

The software will automatically search for the HydroCER-I that is connected (can take a few seconds). When the transmitter is not found you have to choose another COM-port. With Config (Com settings) you can do this (see window below).

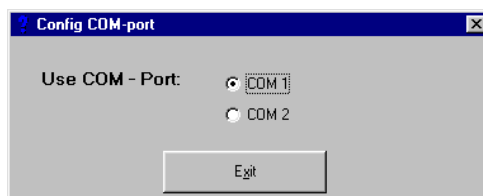

If this also does not work, the connection between the modem and the computer or the connection between the modem and the HydroCER-I must be checked. Push again Connect.

Now the next window appears:

All the settings from the transmitter will be shown.

The information in the white areas can be changed and must be confirmed with **Send**.

Config Data:

Importing or changing the Tag number. This can be figures and letters.

Fixed Data:

The maximum and minimum values from the span and the minimum value from the zero which can be programmed.

Measuring Range:

These are the actual values where the transmitter has been adjusted at.

Zero : the zero which equals 4 mA

Span : the span which equals 20 mA

Unit : the engineering unit which is used for the adjustments on zero and span.

If the *Unit* (engineering unit) is changed, automatically the values for the *zero* and the *span* will be converted to the new *Unit*. (see also the conversion table on the next page).

The values for the *zero* and *span* can be changed within the limits that are shown below **Fixed Data**.

6. CONVERSION TABLE

CONVERSION FACTOR	DISPLAY
1.000	mH ₂ O (mWC)
1000	mmH ₂ O (mm WC)
0.09806	Bar
98.0665	Mbar
1.4223	PSI
0.0967	Atm
9.80665	KPa
0.009807	MPa
0.1	Kgf/cm ²
73.556	mm HG
40.81633	inH ₂ O ("WC)
2.895906	"HG

If the HydroCER-I has be adjusted by using test (air) pressure you have to use the buttons "set current pressure at 4 mA" and "set current pressure at 20 mA".

Set current pressure at 4 mA

The next window appears.

This is the value at 4 mA. In most cases this is the atmospheric pressure.

If the zero must be 0 bar (= atmospheric pressure) push "OK".

After this has been done the main window will appear again (see page 6).

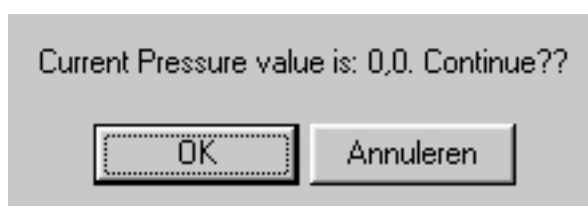

Set current pressure at 20 mA

The next window appears. This is the value at (20 mA). If the *span* must be for example 1,1 bar you have to put test (air) pressure on the diaphragm equal to 1,1 bar. Now push "OK".

After this has been done the main window will appear again.

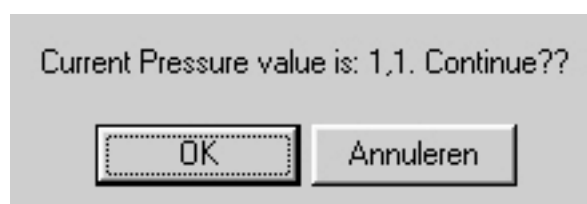

7. EXTRA

Damping: Electronic damping can be adjusted from 0 till 25 seconds.

Output: The transmitter has an output of 4-20 mA as standard.
You can have a reversed output 20-4 mA.

Current Simulation: You can simulate the current between 4 and 20 mA.

Fixed Current (mA): Put the requested current value in the white area and push **<enter>** or **Send**.



The output from the transmitter will now give the imported current. To get another current output, you have to change the value and confirm with **<enter>**.



To quit the current simulation push **Abort**.

Note: If the program has not been closed in a proper way, the current simulation remains active. To abort the simulation the transmitter must be switched off (disconnect the wires).

Error Messages

The next message appears if the *span* will be lower as the *minimum span* or if the *zero* will be lower than the *minimum zero*.

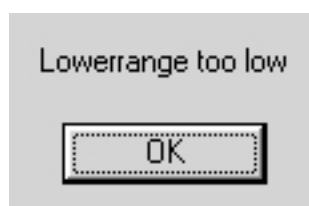

The next message appears if the requested *span* is higher as the *maximum span*.

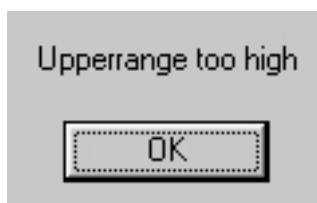

8. TECHNICAL SPECIFICATIONS

<i>Manufacturer</i>	Klay Instruments B.V.	
<i>Instrument</i>	HydroCER-I	
<i>Output</i>	4-20 mA (+ HART [®] Protocol)	
<i>Power supply</i>	Standard : 12 – 36 Vdc HART[®] : 17 – 36 Vdc (Standard) <i>min.</i> 250 Ω	
<i>Accuracy</i>	0,1% from the adjusted range	
<i>Measuring Range: HydroCER-I</i>	Code	Fixed Measuring Range (mWC) Minimum / maximum
	1	0 - 0,5 / 0 – 1,5
	2	0 - 1 / 0 - 4
	3	0 - 3 / 0 - 10
	4	0 - 10 / 0 - 20
<i>Process temperature</i>	-10° C tot + 70° C (- 14° F tot + 158° F)	
<i>Ambient temperature</i>	-10° C tot +70° C (-14° F tot + 158° F)	
<i>Damping</i>	0,5 till 25 seconds (free adjustable) Factory setting: 0,5 second	
<i>Protection grade</i>	IP 68 (only the submersible parts) IP 65 (the venting tube at the end of the cable)	
<i>Material wetted parts:</i>	Foot and connection: AISI 316 Diaphragm: Ceramic Cable: Poly Ethylene (PE) Sealing between Cable and connection: Viton <i>Other materials on request</i>	

Technical specifications can change without notice.

9. ADVISEMENTS and WARNINGS

We herewith give a list of some advisements and warnings concerning the application and installation of the electronic level transmitters, the HydroCER-I:

- Check if the specifications of the HydroCER-I meet the needs of the process conditions.
- To achieve the most accurate measurement with the HydroCER-I, be aware of the place where the transmitter is mounted. Here are some advises:
 - Don not mount a level transmitter in- or near filling or discharging pipes.
 - In case of automatic cleaning systems or hand cleaning: never point the water jets on the sensor, take necessary steps to avoid this.

Warranty will not be granted if the sensor is damaged.

- The sensor of the HydroCER-I is protected with a special protection cab. Prevent damaging of the sensor. Warranty will not be granted.
- The venting at the end of the cable must be placed in an absolute dry area to prevent moisture coming into the transmitter. For a good venting a special junction box can be delivered as an option. This junction box has a protection grade of IP 66 and has a special venting nipple. Dimensions: 80 x 75 x 76.
- Avoid high pressure water-jets pointed at the venting.
- WARRANTY: The warranty is 1 year after delivery date. Klay Instruments B.V. does not accept liability for consequential damage of any kind due to use or misuse of the HydroCER-I. Warranty will be given, to be decided by the manufacturer. Transmitter must be shipped free of charge to the factory. Klay Instruments B.V. is not an expert in the customer's process (technical field) and therefore does not warrant the suitability of its product for the application selected by the customer.
- Klay Instruments reserves the right to change its specifications at any time, without notice.
- CE / EMC - Rules: All Klay transmitters are manufactured in accordance with the RFI / EMC directives and comply with the CE standard. All transmitters are fitted with RFI filters, which provide optimum, trouble-free operation. Our products are in conformity with EMC-Directive 2004/108/EC based on test results using harmonized standards.

Manufactured by:

 **KLAY-INSTRUMENTS**
www.klay.nl

Nijverheidsweg 5
P.O. Box 13
Tel: +31-521-591550
Fax: +31-521-592046

7991 CZ DWINGELOO
7900 AA DWINGELOO
The Netherlands
Email: info@klay.nl