

KLAY-INSTRUMENTS

INSTRUCTION MANUAL
"Intelligent" Pressure and level transmitters

SERIES 3000

SERIES 3000-SAN



HART 
COMMUNICATION PROTOCOL



Read the recommendations and warnings in this manual before the instrument is installed. For personal safety, optimal use and maintenance of the Series 4000 and 4000 SAN, these instructions must be studied carefully.

Manufactured by:

 **KLAY-INSTRUMENTS**

www.klay-instruments.com

Nijverheidsweg 5
P.O. Box 13
Tel: +31-521-591550
Fax: +31-521-592046

7991 CZ DWINGELOO
7990 AA DWINGELOO
The Netherlands
E-Mail: info@klay.nl

TABLE OF CONTENTS

CHAPTER		PAGE
1	Introduction	3
1.1	Description Series 3000-SAN	3
1.2	Description Series 3000	3
1.3	Barometric Reference	3
2	Dimensions	4
2.1	Dimensions Series 3000-SAN	4
2.2	Dimensions Series 3000	4
3	Installing the Transmitter	5
3.1	Welding instruction	5
3.2	Installing Series 3000-SAN	5
3.3	Installing Series 3000	5
3.4	Mounting position	5
3.5	Mounting position effect	6
3.6	Calibration	6
3.7	Wiring	6
4	Remaining	6
4.1	Digital Local Indicator	6
4.2	CE / EMC - Rules	6
4.3	External load	7
4.4	Traceability / Year of Manufacturing	7
5	Functions of push buttons	7
6	Program Points (P101 t/m P115)	8
7	Readout on display	9
8	Explanation programming points	9
	P101 Zero adjustment (Zero)	9
	P102 Span adjustment (Span)	9
	P103 Cancel mounting position effect	10
	P104 Adjustment pressure unit	10
	P105 Output selection: 4-20 mA or 20-4 mA	11
	P106 Damping adjustment	11
	P107 Sensor temperature indication	11
	P108 Temperature °F or °C	11
	P109 Display readout	12
	P110 Current simulation (4-20 mA)	12
	P111 Linearization	13/15
	P113 Write protection	15
	P114 Response time pushbuttons	15
	P115 Burst Mode	15/16
9	Programming the Series 3000	16
9.1	Programming with Hand Held Terminal	16
9.2	Programming with DTM	16
9.3	Programming with PDM	16
10	Specifications	17
11	Precautions and warnings	18

1. Introduction

The Series 3000 are pressure and level transmitters with a capacitive ceramic sensor. The Ceramic sensor is mounted in a stainless steel process connection and sealed with a Viton O-Ring (other O-Ring materials on request). The Series 3000 has no oil filling. Pressure on ceramic sensor will change the capacity of the sensor, the electronics detects the change of capacity and translates this into a 4-20 mA signal. The Series 3000 has a perfect long term stability.

The Series 3000 and 3000-SAN are fully temperature compensated. The ceramic sensor has a temperature sensor that measures the process temperature. The output signal is compensated against temperature changes and has a long term stability. Calibration can be done very easy by 3 pushbuttons and a display without using reference pressure.

1.1 Series 3000-SAN

The Series 3000-SAN is designed with a Flush Mounted ceramic sensor. Typical applications are Pressure and Hydrostatic Level measurement in slurries, pulp & paper stock and other clogging media.

They also can be used in the Food & beverage industry however we recommend to use the Klay series 2000-SAN or 4000-SAN with a strong Stainless Steel flush diaphragm. These diaphragms are fully welded and are all certified according to EHEDG and 3A. They fully meet the needs of the food, pharma and chemical industries.

1.2 Series 3000

The Series 3000 is specially designed for the pulp and paper, mining and similar industries, where clogging is a problem. All common pulp and paper process connections are available. All other industrial process connection are available as standard too.

1.3 BAROMETRIC REFERENCE

The Series 3000 and 3000-SAN is in basic a so called Relative Transmitter which means that barometric changes will not affect the zero (4 mA). The venting is placed in the cover of the electronics housing and is the filter for the barometric reference to atmospheric pressure. The venting must be kept clean.

Absolute transmitters are available as an option.

2. DIMENSIONAL DRAWINGS

2.1 Series 3000-SAN (Code W)

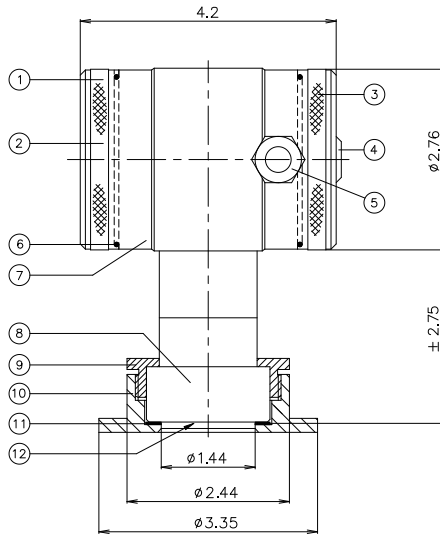

- | | | |
|-----|-------------------------|--------------------------------|
| 1. | Cover | AISI 304 |
| 2. | Pushbuttons and Display | |
| 3. | Cover with venting | AISI 304 |
| 4. | Venting | PA |
| 5. | PG Cable gland | |
| 6. | O-Ring (2 pcs.) | EPDM |
| 7. | Electronics housing | AISI 304 |
| 8. | Sensor foot | AISI 316 |
| 9. | Lock ring | AISI 304 |
| 10. | Weldon adaptor | AISI 316 L |
| 11. | Gasket | PTFE |
| 12. | Ceramic Sensor | Al ₂ O ₃ |

2.2 Series 3000 (X3)

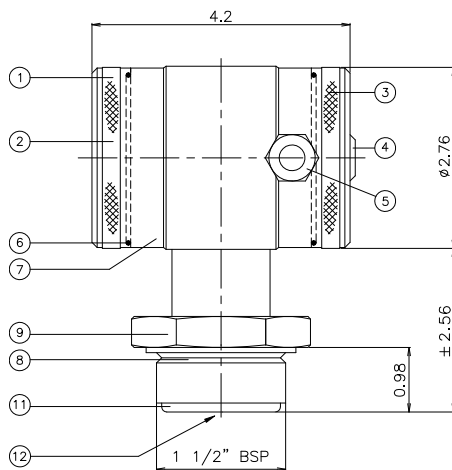

- | | | |
|-----|-------------------------|--------------------------------|
| 1. | Cover | AISI 304 |
| 2. | Pushbuttons and Display | |
| 3. | Cover with venting | AISI 304 |
| 4. | Venting | PA |
| 5. | PG Cable gland | |
| 6. | O-Ring (2 pcs.) | EPDM |
| 7. | Electronics housing | AISI 304 |
| 8. | 1 1/2" BSP | AISI 316L |
| 9. | Hexagon SW60 | AISI 316L |
| 11. | O-Ring | Viton |
| 12. | Ceramic sensor | Al ₂ O ₃ |

2.3 Series 3000 (W33)

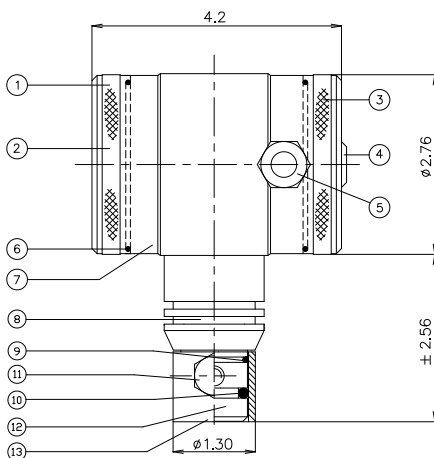

- | | | |
|-----|-------------------------------|------------|
| 1. | Cover | AISI 304 |
| 2. | Pushbuttons and Display | |
| 3. | Cover with venting | AISI 304 |
| 4. | Venting | PA |
| 5. | PG Cable gland | |
| 6. | O-Ring (2 pcs.) | EPDM |
| 7. | Electronics housing | AISI 304 |
| 8. | Sensor foot with cooling fins | AISI 316 |
| 9. | O-Ring | Viton |
| 10. | O-Ring | Viton |
| 11. | M8 bolt | AISI 316 |
| 12. | Diaphragm and Ring | AISI 316 |
| 13. | Weldon adaptor ϕ 33 mm | AISI 316 L |

2.4 SEALING CERAMIC SENSOR

The ceramic sensor is sealed with an O-Ring (see illustration) ⑪. A seal (O-Ring) from Viton is used as standard. Depending on the medium, other materials can be provided such as EPDM or KALREZ, please contact Klay Instruments.

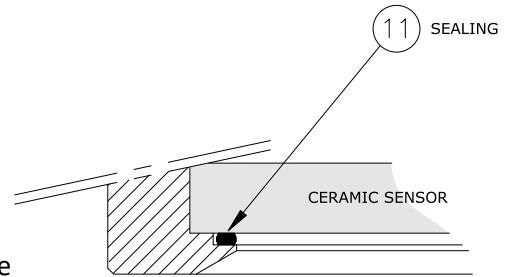

3 TRANSMITTER INSTALLATION

The sensor of the transmitter is protected by a protection cap. Remove the protection cap just before installation takes place. Damage to the Ceramic sensor must always be prevented.

3.1 WELDING INSTRUCTION

A certified welder should perform installation of the weld-on adaptor. Weld with Argon, MIG or TIG. The smallest welding pin must be used.

1. Cut a hole in the process vessel/pipe to accept the weld-on adaptor.
2. Prepare the hole by beveling the edge to accept filler material.
3. Remove the weld-on adaptor from the transmitter.
4. Remove the PTFE packing before welding.

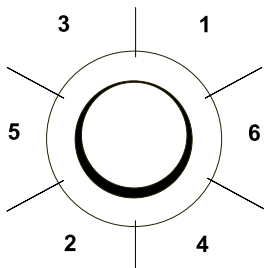

WARNING

Improper installation may result in distortion of the weld-on adaptor. Excessive heat will distort the weld-on adaptor. Weld in sections as shown in the figure left. Allow adequate cooling between passes. To reduce the chances of distortion to the weld-on adaptor, use a mandrel.

Series 3000-SAN : Part.no: 1019
 Series 3000 : Part.no: 1016

Determine (before welding) the position of the electronic housing, so that the cable entry and the venting are in the right position. After welding these positions are fixed.

5. Position the weld-on adaptor in the vessel hole and tack six places. The weld sequence is shown in the figure above.
6. Weld the weld-on adaptor in place using 0.03 to 0.045 inch. (0.762 to 1.143 mm) stainless rod as filler material in the beveled area. Adjust amperage for penetration.
7. Remove the mandrel after the welding operation.

3.2 INSTALLING SERIES 3000-SAN (Code W)

1. Make sure to correctly locate the packing within the weld-on adaptor.
2. Improper installation of the packing can cause a process leak.
3. Position the transmitter into the weld-on adaptor and begin engaging threads.
4. The transmitter can be rotated prior to seating enabling the user to optimize access to calibration adjustments, cable entry, and local indicator.
5. Once the Lock ring ⑨ has been hand tightened, it must be tightened with an additional turn with adjustable pliers ($\pm 1/8''$).

3.3 INSTALLATIE SERIES 3000 (W33)

1. After welding, clean up edges, and take care of the inside adaptor wall.
2. Make sure the O-Ring ⑨ and ⑩ are properly located.

- Improper installation at the O-Ring can cause a process leak.
- 3. Apply silicone grease to the O-Ring, diaphragm ring and the hole inside wall of the weld-on adaptor, this prevents galvanic cell corrosion between transmitter and adaptor inside.
- 4. Install the transmitter and fix it with the AISI M8 bolt.

3.4 MONTING POSITION

When the transmitter is mounted horizontally, the cable gland must be pointed downwards.

3.5 MONTAGE STAND EFFECT

Depending on how the transmitters is mount a small mounting position effect can occur. This effect can be canceled with program point P103. The span will not be effected.

3.6 CALIBRATION

All transmitters are fully calibrated at the factory, to customer specified range. If calibration is not specified, the transmitter will be calibrated at the maximum span.

3.7 WIRING

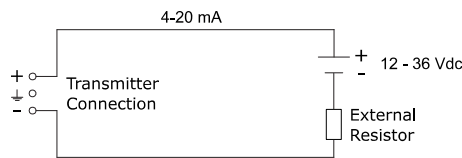

Under the cover ③ you will find the terminal board. The push buttons *Zero*, *Span* and *Prog* are under the other cover ①. External loads must be placed in the negative side of the 2-wire loop.

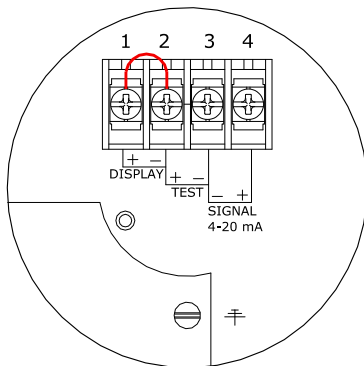

The figure left shows the wiring connection of the transmitter. The 2 Wires must be connected to 3 (-) and 4 (+).

The transmitter must always be connected to earth. The transmitter must be connected with standard two-wire shielded cable. Do not run signal wiring in open trays with power wiring, or near heavy electrical equipment (Frequency controller or heavy pumps). Shielding must always be connected at the side of the power supply. In case the process connection is already connected to ground (e.g. via the tank or pipe line) Do not connect the instrument to ground. Please ensure that the instrument is **not** connected to ground twice to prevent an 'earth loop'.

In applications with synthetic process connections, the transmitter must be connected to ground. Reversing the polarity will not damage the transmitter, the transmitter will not function until the + and – are properly connected.

4. REMAINING

4.1 DIGITAL LOCAL INDICATOR

All transmitters from the Series 3000 are standard equipped with a digital display. As standard transmitters are delivered with closed covers. The three push buttons and the display are behind the cover (1). As an option an Transparent cover can be delivered to achieve the display can be used as a local display in the process. The display can be set to any value between 0000 and 9999 (4 digit). (Option: "I" extra price).

4.2 CE / EMC - RULES

All Klay transmitters are manufactured in accordance with the RFI/EMC directives and comply with the CE standard. All transmitters are fitted with RFI filters, which provide optimum, trouble-free operation. Our products are in conformity with EMC-Directive 2014/30/EU based on test results using harmonized standards.

4.3 EXTERNAL LOAD

The minimum power supply is based on the total circuit resistance. The maximum permissible load ($R_i \max.$) in case of 24 Vdc is 600 Ω (Ohm).

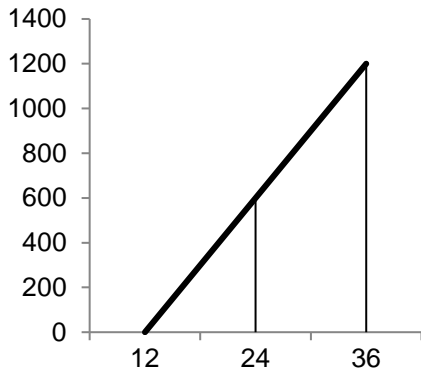

By increasing the power supply, the external load can be increased to 1200 Ohm / 36 Vdc. (see figure left).

$$R_i \max = \frac{\text{Power supply} - 12 \text{ Vdc (min. supply)}}{20 \text{ mA}}$$



With a loop resistance of 250 Ω a power supply of at least 17 Vdc must be used.

4.4 TRACEABILITY YEAR OF MANUFACTURING

The year of manufacturing of the transmitter can be traced as follows: take the first three numbers from the serial number that is engraved in the transmitter and add 1700 to it. For example: if the serial number is 31802123. The year of manufacturing is 1700 + 318 = 2018.

5 PUSHBUTTONS

The Series 3000 can be programmed easily by use of the 3 front panel pushbuttons. The display can show engineering units of: mH2O, inH2O, bar and PSI.

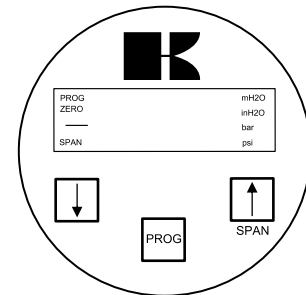

The functions of the three pushbuttons will be explained below.



This button has 2 functions: It can be directly used for adjusting the zero (4 mA), with or without a test pressure. When the zero (4 mA) must be adjusted at 0 (atmospheric pressure), the button must be held until the word "Zero" appears on the display. The transmitter is now set to 4 mA.

This button must be used for stepping down in the menu or to decrease a value (-).



For canceling the mounting position effect you have to use P103.



This button has 2 functions: It can be directly used for adjusting the span (20 mA), when using a test pressure (air). When a test pressure (e.g. 2 bar) is supplied to the transmitter, the button must be held until the word "SPAN" appears on the display. The transmitter is adjusted at 20 mA now. The span can also be adjusted without test pressure (see P102).

This button must be used for stepping up in the menu or to increase a value (+).



This button has 2 functions: It is used to adjust the Programming Points (P101 till P114). Push it once and P100 is displayed, use the [↑] (SPAN) to step to P101. This button must also be used for confirming the adjustments (enter). For example, if you want to change the adjustment in psi (P104), the following steps must be taken:

1. Push on [PROG] till "100" appears on the display.
2. Push on [SPAN] 4 times to go to point "P104" (adjustment pressure unit).
3. Push [PROG] to confirm this.
4. Push several times on [↑] (SPAN) to reach 3 (= bar). (Conversion table page 11).
5. 1 = mWC, 3 = bar, 5 = psi, 11 = inWC
6. Confirm this by pushing once at [PROG].
7. The transmitter is now adjusted to read in psi.

6. PROGRAMMING POINTS

The following points can be adjusted with the three push buttons. For an explanation of these points see the following pages of this manual.

To change one of these points you have to push on [PROG] until "100" appears on the display.

To go from a lower program (P101) to a higher one (P102), push on button [↑] (SPAN). To confirm the adjustments you always have to press on [PROG].

*) Standard adjustments ex works.

P101	Zero adjustment (4 mA)
P102	Span adjustment (20 mA)
P103	Cancel mounting position effect
P104	Adjustment pressure unit (See Conversion table)
P105	4-20 mA (*) 20-4 mA (Reverse output)
P106	Adjustment damping (0 to 25 sec)
P107	Indication of process temp. (Read out on display)
P108	0 = °C (*) 1 = °F
P109	Read out on display: Curr (0) = Current (4 - 20 mA) (*) Unit (1) = Pressure unit (conversion table) PerC (2) = Percentage TenP (3) = Temperature Hect (4) = Hectoliters CBn (5) = Cubic meters Ltr (6) = Liters
P110	Simulation of current
P111	Linearization 0 = No Linearization (*) 1 = Cylindrical tank 2 = Vertical tank with cone 3 = Vertical tank with spherical cone
P113	Lo.Pr= Local Protection (OFF/ON) Co.Pr= Com Protection. (OFF/ON)
P114	Response time from push buttons
P116	Absolute / Relative
P117	Service menu

7. READING ON THE DISPLAY

On the standard built-in display several values can be shown. When the transmitter is in the process the display gives all the information of the process pressure or temperature. On the display the following units are available: mH₂O, inH₂O, bar and psi (see P104 and P109).

PROG	mH ₂ O
ZERO	inH ₂ O
—	bar
SPAN	psi



As standard the transmitter is supplied with two "closed" covers protecting the buttons and the display. As an option an "open" cover (IP 66) can be fitted. The display can then be used as a local process display. (Option: "I" extra price). The full scale can be set between -9999 and 9999 (4 digit).

8. EXPLANATION PROGRAMMING POINTS

P101

ZERO ADJUSTMENT (4 mA)

The transmitter as standard is adjusted to 4.00 mA at atmospheric pressure. It is also possible to adjust a zero-suppression or elevation.

For example: Zero elevation of 1.45 psi.

1. Push at [PROG] until **100** is shown on the display.
2. Push once at [↑] / SPAN till **101**.
3. Confirm this by pushing [PROG].
4. Now the display will show 0.00 mH₂O. Push at [↑] till 1.45 psi is on the display.
5. Confirm with [PROG].
6. The output of the transmitter will be lower than 4 mA. The output at atmospheric pressure will be for example 3.68 mA. When a pressure of 1.45 psi is applied on the diaphragm the output will be 4.00 mA.

The elevation can be canceled by pushing at [↓] till zero disappears out of the display. The transmitter is now adjusted at 4 mA at atmospheric pressure.

P102

SPAN ADJUSTMENT (20 mA) WITHOUT TEST PRESSURE

Before adjusting the span take care the right pressure unit is selected. (See also P104 and P109).

Example: Adjustment of the span at 0 - 29 psi.

The pressure unit must be adjusted at psi. (See P104).

1. Push [PROG] till **100** is shown on the display.
2. Push twice at [↑] / SPAN until **102** appears on the display.
3. Confirm this by pushing [PROG].
4. Push [SPAN] (+) or [ZERO] (-) to select the measuring range that is required.
5. Confirm by pushing [PROG]. The transmitter is adjusted now.



P102 is the adjustment of the total span. When a compound range must be adjusted (for example -14.5 till +43.5 psi), a span of 58 psi must be programmed. The Zero (P101) must be set at -14.5 psi. The transmitter is adjusted at -14.5 psi = Zero and +43.5 psi = Span.

P103

CANCEL MOUNTING POSITION EFFECT

All transmitters are calibrated vertically. When a transmitter of the Series 3000 or 3000-SAN is installed horizontally, there will be a small "mounting effect" on the zero (4 mA). For example the transmitter shows 4.03 mA instead of 4.00 mA. This can be easily canceled with P103. In P103 there are three options:

ESC Nothing will be changed. Leave without doing anything. (confirm with PROG).

RESET Use this option when you are not sure if P103/SET has been done in a proper way. (confirm with PROG). When using this option the original factory setting will be valid.

SET Canceling mounting position effect. (confirm with PROG). When SET is selected the transmitter is automatically adjusted at 4.00 mA. The span will not be affected.

Do not apply pressure while executing "cancel mounting position effect"

P104

ADJUSTMENT PRESSURE UNIT ON DISPLAY (See Conversion table)

Several engineering units can be shown on the display by using a conversion factor. (See conversion table below). As standard the pressure unit of the transmitter is set to bar. Four engineering units can be used for displaying the applied pressure on the display (mH₂O, inH₂O, bar and psi).

This will be explained with an example (psi):

1. Push at [PROG] till **100** is shown on the display.
2. Push 4 times at [↑], go to **P104**. Push at [PROG] to confirm this.
3. Push at [↑] and adjust at 5 (= psi).
1 = mH₂O (= mWC), 3 = bar, 5 = psi, 11 = inH₂O (= inWC).
4. Confirm with [PROG]. The transmitter will now read out in psi.

CONVERSION TABLE

104	CONVERSION FACTOR	DISPLAY
1	1.000	mH ₂ O (mWC) *
2	1000	mmH ₂ O (mmWC)
3	0.09806	bar *
4	98.0665	mbar
5	1.4223	psi *
6	0.0967	atm
7	9.80665	kPa
8	0.009807	MPa
9	0.1	kgf/cm ²
10	73.556	mmHg
11	39.37	inH ₂ O (inWC) *
12	2.895906	inHg

To show one of the engineering units, P109 must be adjusted at 1 (= Pressure unit).

*) Pressure units that can be shown on the display. When the value of the highest range is larger than 9999, "NA" will appear in the display (Not Applicable). Another unit must be chosen.

P105

REVERSE OUTPUT (20 - 4 mA)

The transmitter as standard is adjusted to 4-20 mA output.

Push on [PROG] and go to **P105**.

Push once at [↑] to change the output to 20-4 mA (Reverse output).

Push at [PROG] to confirm this.

Now the transmitter will give 20 mA at atmospheric pressure.

P106**ADJUSTMENT DAMPING (0 till 25 sec)**

In P106 an electronic damping can be adjusted between 0 and 25 seconds. This can be done with the push buttons [↑] (up) and [↓] (down). Always confirm by pushing once at [PROG].

P107**INDICATION OF PROCESS TEMPERATURE (READ OUT ON DISPLAY)**

Push [PROG] until **100** is shown on the display.
Push 7 times at [↑], go to **P107**.
Push [PROG] to confirm this. Now the process temperature appears on the display (Indication: +/-2°C).

This will remain on the display. To get the actual pressure back on the display you have to push again on P107 until the actual pressure appears on the display again.

P108**CONFIGURATION**

AoUt: Alarm output. The alarm output has 2 choices: LoU (low) or High (High): Low is the lower limit of the lowest permissible current value. High is the upper limit of the highest permissible current value. If the above limits are exceeded, the output is output with alarm output low or high. The alarm output values are set to Low 3.2 mA and High 22.8 mA.

TEnP: As standard, the readout of the temperature of the transmitter is set) °F (FAHR). Push in P108 on [↑] to change to °C (CELC). Always confirm with [PROG].

Lpro: Local Protection: Changes with the pushbuttons

1. Push [PROG] until **100** is shown on the display
2. Push 8 times at [↑], go to **P108**.
3. Push [PROG] to confirm this.
4. Push [↑] until "LPro" appears on the display.
5. Push [PROG] to confirm this option.

Cpro: Communication Protection: Changes externally by **HART** or **PC**

1. Push [PROG] until **100** is shown on the display
2. Push 8 times at [↑], go to **P108**.
3. Push [PROG] to confirm this.
4. Push [↑] until "CPro" appears on the display.
5. Push [PROG] to confirm this option.

When Local Protection is on, in P104, P105, P107, P108, P109 and P111 the message "PROT" (Protected) appears on the display. Both options can be set independently. As standard both protections are not enabled.

hArt: With this option the version can be chosen. **hAr5** is HART 5 and **hAr7** is HART 7. Push in P108 on [↑] to select the desired choice. Push [PROG] to confirm the selected HART version.

P109**READ OUT ON DISPLAY**

Curr (0) = current	(4 - 20 mA)
Unit (1) = pressure unit	(See conversion table)
PErC (2) = percentages	(0 - 100%)

TEnP (3) = temperature	(°F of °C) Indication of process temperature, accuracy depending on sensor position.
HEct (4) = hectoliter	(only in combination with P111)
Cb n (5) = Cubic meter	(only in combination with P111)
Ltr (6) = Liters	(only in combination with P111)
FREE (7) = Free adjustable scale	(only in combination with P111)

As standard the transmitter read out is in mA (0). To change this, follow the next steps:

1. Push [PROG] until **100** is shown on the display.
2. Push 9 times at [↑] / SPAN till **109** appears on the display.
3. Confirm with [PROG].
4. Push once at [↑].
5. Push [PROG] to confirm this.
The transmitter will now read mH₂O (mWC).
The pressure unit can be changed with the conversion table in P104.
1 = mH₂O (=mWC), 3 = bar, 5 = psi, 11 = inH₂O (inWC).

The read out can also be in 0 - 100%. Select P109, option 2.

P110

SIMULATION OF CURRENT (4-20 mA)

The transmitter can be used as a simulator of a current between 4 - 20 mA.
The user can perform a current simulation (Curr) or a pressure simulation (Unit).

Current-simulation (Curr)

To perform a current-simulation follow the next steps:

1. Push [PROG] until "**100**" is shown on the display.
2. Push 10 times at [↑] / SPAN till **110** appears on the display. Confirm with [PROG].
3. The display will readout 'Curr'
4. Confirm with [PROG].
5. The display shows '4.00'. Push [PROG] and the output changes to 4.00 mA.
6. By pushing [↑] / SPAN or [↓] / ZERO, you can change the value on the display. The output value will change as soon as the [↑] / SPAN OR [↓] / ZERO button is released.
7. Press [PROG] to exit the simulation.

Pressure-simulation (Unit)

To perform a pressure-simulation follow the next steps:

1. Push [PROG] until "**100**" is shown on the display.
2. Push 10 times at [↑] / SPAN till **110** appears on the display.
3. Confirm with [PROG].
4. The display will readout 'Curr'
5. Press [↑] / SPAN once
6. The display will readout 'Unit'.
7. Confirm with [PROG].
8. The display shows a pressure value. Push [PROG] and the output changes to a mA-output corresponding with the range entered in menu P101 and P102.
9. By pushing [↑] / SPAN or [↓] / ZERO, you can change the value on the display. The output value will change as soon as the [↑] / SPAN or [↓] / ZERO button is released.
10. Pressing the [PROG] button again will exit the simulation.

The values that can be entered using the pressure-simulation are related to the adjustments in menu P101 and P102. These values are also the minimum and maximum values.
 HART: This menu will not work when the device is operating in multi-drop mode.

P111

LINEARIZATION

- 0 = no Linearization
- 1 = cylindrical tank (horizontal)
- 2 = tank with bottom cone
- 3 = tank with spherical bottom
- 4 = Free adjustable scale (Linear) (Option G79)

As standard the transmitter is delivered without Linearization (= 0). However, for a horizontal tank or a tank with a bottom cone, a Linearization can be applied to achieve the current signal (mA) is equal to the level in the tank. All values must be programmed in meters.

Linearization horizontal tank (Cylindrical)

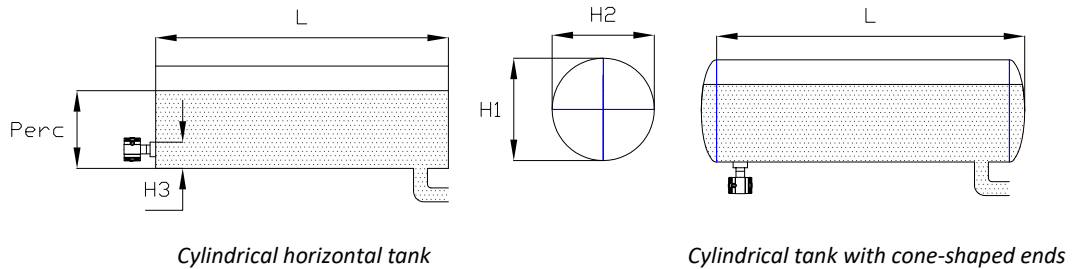

1. Push [PROG] until **100** is shown on the display.
2. Push 11 x at [↑] / SPAN till **111** appears. (Confirm with [PROG])
3. Push [↑] once. (Confirm with [PROG])
4. Enter the height (H1) of the tank in meters. (Confirm with [PROG])
5. Enter the same height (H2) of the tank in meters. (Confirm with [PROG])
6. Enter the length (L) of the tank. For a "ball" or cone shaped tank, take the cylindrical length plus the length of 1 "ball" cone. (Confirm with [PROG])
7. Enter H3 in meters if the transmitter is installed like in the left picture. Enter 0m when the transmitter is installed like in the right picture.
8. Enter the percentage of the actual "full" level (for example 80%). (Confirm with [PROG]).

Linearization horizontal tank (Elliptic)

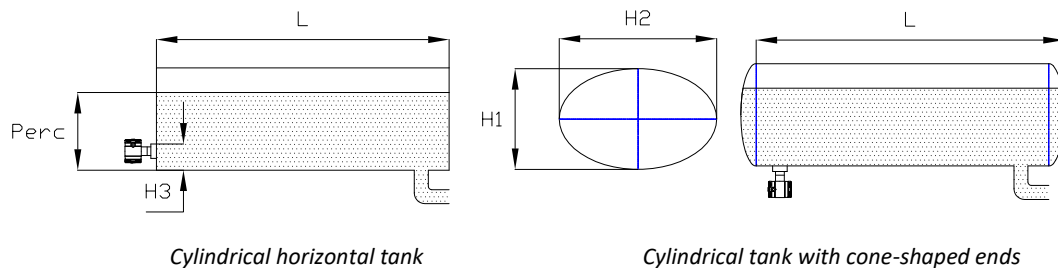

1. Push [PROG] until **100** is shown on the display.
2. Push 11 x at [↑] / SPAN till **111** appears. (Confirm with [PROG])

3. Push [\uparrow] once. (Confirm with [PROG])
4. Enter the height (H1) of the tank in meters. (Confirm with [PROG])
5. Enter the height (H2) of the tank in meters. (Confirm with [PROG])
6. Enter the length (L) of the tank. For a "ball" or cone shaped tank, take the cylindrical length plus the length of 1 "ball" cone. (Confirm with [PROG])
7. Enter H3 in meters if the transmitter is installed like in the left picture. Enter 0m when the transmitter is installed like the right picture.
8. Enter the percentage of the actual "full" level (for example 80%). (Confirm with [PROG]).

If the height (H) of the tank is 1 meter and the maximum level in the tank is 0,8 meter the percentage (point 8) must be set at 80%. The calibration at P102 must be adjusted at: 1 meter (if specific gravity equals 1).

Linearization vertical tank with cone

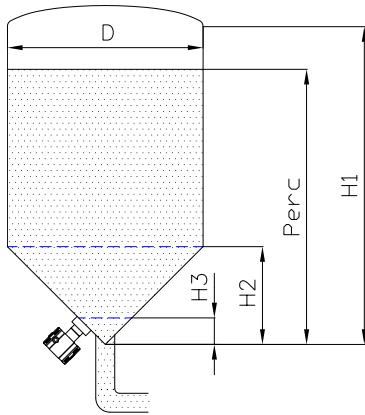

1. Push [PROG] till **100** appears on the display.
2. Push 11 times at [\uparrow] till **111** appears.
3. (Confirm with [PROG])
4. Push twice at [\uparrow]. (Confirm with [PROG])
5. Enter height (H1) of the tank (= actual level). (Confirm with [PROG]).
6. Enter diameter (D) of tank. (Confirm with [PROG])
7. Enter height (H2) of cone. (Confirm with [PROG])
8. Enter the height (H3) from the bottom of the tank to the topside of the diaphragm (or weld-on adaptor). (Confirm with [PROG]).
9. Enter the percentage of the actual "full" level (for example 80%).(Confirm with [PROG]).

Linearization vertical tank with spherical cone

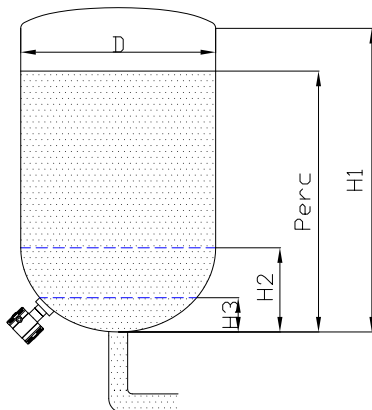

1. Push [PROG] till **100** appears on the display.
2. Push 11 times at [\uparrow] till **111** appears.
3. (Confirm with [PROG])
4. Push three times at [\uparrow]. (Confirm with [PROG])
5. Enter height (H1) of the tank (= actual level). (Confirm with [PROG]).
6. Enter diameter (D) of tank. (Confirm with [PROG])
7. Enter height (H2) of cone. (Confirm with [PROG])
8. Enter the height (H3) from the bottom of the tank to the topside of the diaphragm (or weld-on adaptor) (Confirm with [PROG]).
9. Enter the percentage of the actual "full" level (for example 80%).(Confirm with [PROG]).

*When the specific gravity of the fluid is unequal to 1 and you do not want to use option 4, you must take care of defining of the **calibration** of the transmitter. Calibration (see P102) = Height of the level x Specific Gravity.*

FREE ADJUSTABLE SCALE (Option G79)

1. Push [PROG] till "100" appears on the display.
2. Push 11 times at [↑] till "111" appears. Confirm with [PROG].
3. Navigate to FREE with the arrow [↑] buttons. (Confirm with [PROG])
4. The next step is entering the amount of digits of the reading. With the arrow [↑] buttons the decimal can be changed to left or right.
5. SET MIN appears on the display, and the minimum value can be set, by using the arrow [↑] buttons. Confirm with [PROG]).
6. SET MAX appears on the display, and the maximum value can be set, by using the arrow [↑] buttons. Confirm with [PROG].
7. To display this configuration on the display navigate to P109. Choose FREE and confirm with [PROG].

P114**PUSHBUTTONS RESPONSETIME**

The response time of the Pushbuttons can be adjusted from 0.5 to 5.0 seconds.

P115**BURST MODE**

The transmitter (if HART® output available) can be set for Burst mode, the continuous transmission of HART® messages. (Only possible with HART 7).

1. Push [PROG] until **100** is shown on the display
2. Push on [↑] until **111** appears on the display. Confirm with [PROG].
3. There are three options: 0, 1 and 2. With these choices 3 different types of burst messages can be configured.

9 PROGRAMMING THE SERIES 2000



When using HART® or a Hand Held Terminal (HHT), a minimum resistance of 250 ohms **must** be present in the loop of the 2-wire system. This is necessary for proper communication (see drawing below). A power supply of at least **17 Vdc** must be used.

9.1. PROGRAMMING WITH THE HAND HELD TERMINAL

The Series 3000 can be easily programmed with the Hand Held Terminal (HHT) from the "HART Foundation" or the HHT from "Rosemount" (type 275 or 375 Hart Communicator).

Option 1: HART® Handheld terminal connected across the transmitter.

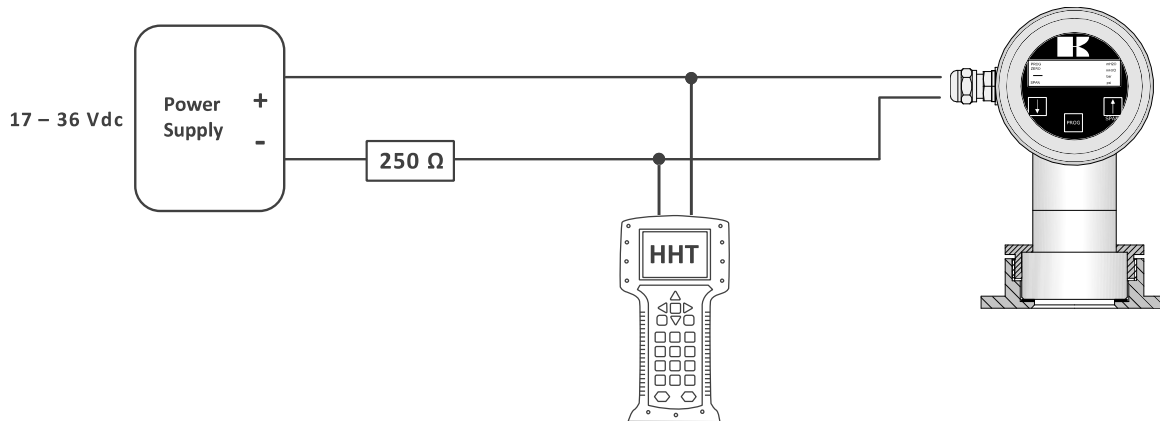

Option 2: HART® Handheld terminal connected across the loop resistor.

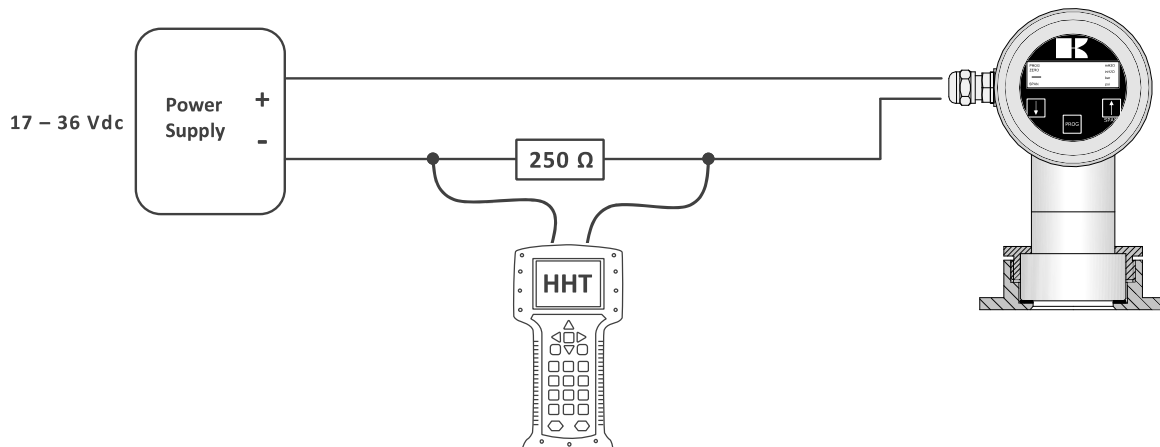

9.2 PROGRAMMING WITH DTM

A DTM is available (with each FDT container to use). A separate manual is available for this. The DTM can be downloaded from www.klay.nl under the downloads category. For the Series 3000 the DTM of the Series 2000 must be used. Start the installation by extracting the file and then opening the Klay Series 2000 HART.exe file.

9.3 PROGRAMMING WITH PDM

A Device Description (DD) is available for configuration using Siemens Simatic PDM.

The DD can be downloaded from www.klay.nl under category downloads. For the Series 3000 the DTM of the Series 2000 must be used. Extract the file and install the DD using the DeviceInstall.exe program.

10. SPECIFICATIONS				
Manufacturer	Klay Instruments			
Instrument	Series 3000, Series 3000-SAN			
Output	4-20 mA Optional: HART® Protocol			
Power Supply	Standard : 12 – 36 Vdc HART® : 17 – 36 Vdc (Standard) min. 250 Ω			
Accuracy	0.2 % of adjusted span (Option 0.1 %)			
Ranges	Code	Adjustable span ranges		Max. overpressure
Series 3000 and 3000-SAN	1	0 - 40 "H ₂ O	0 - 14.5 psi	90 psi
	2	0 - 80 "H ₂ O	0 - 29 psi	180 psi
	3	0 - 7.5 psi	0 - 75 psi	360 psi
	4	0 - 29 psi	0 - 290 psi	650 psi
	5	0 - 75 psi	0 - 750 psi	1200 psi
Process temperature ¹				
Series 3000	-4 °F till 176 °F			
Series 3000-SAN	-4 °F till 212 °F			
Ambient temperature	-4 °F till 158 °F			
Damping	0.0 sec. till 25 sec. Standard damping: 0.0 sec.			
Ingress protection	IP66			
Material	Housing	AISI 304 (Optional AISI 316)		
	Wetted parts	Ceramic sensor Al ₂ O ₃ (99.9 %)		

¹ For higher temperatures use other kind of pressure transmitters. Contact Klay Instruments for information..

11. PRECAUTIONS and WARNINGS

- Check if the specifications of the transmitter meet the needs of the process conditions
- To obtain the most accurate measurement possible with a level transmitter, the location of the transmitter is very important. Here are some advices:
 - DO NOT mount a level transmitter in- or near filling or discharging pipes.
 - In case of automatic cleaning systems or hand cleaning: never point the water jets on the diaphragm, take necessary steps to avoid this. Warranty will not be granted.

Damage to the sensor is not covered by the warranty.

- The Series 3000-SAN must be used for level measurement on chemicals.

When a pressure transmitter is used in a pipe, the following must be taking into account:

- Quick-closing valves in combination with high flow rates can cause water spikes. This can damage the transmitter. Make sure that the transmitter is not placed too close to such a valve, but always behind a number of bends in the pipe.
- A transmitter that is under the influence of a plunger pump must also be placed behind a number of bends in the pipe.

Welding advice:

- This is very important to prevent distortion of the weld-on adaptors. It also prevents the screw thread from the Series 3000-SAN from being deformed. Never weld the entire circumference at once.
- The membrane of the transmitter is protected by a protective cap. Do not remove this protective cover just before installation to prevent damage to the diaphragm. Do not push with sharp objects against the membrane.
- As soon as the wiring is brought inside through the PG9 cable gland and connected to the terminal board, make sure the cable gland is tightly fixed, so that moisture cannot enter into the electronic housing.
- The transmitter is fitted with a special venting device (3), which is specially designed to prevent moisture penetration into the housing. If the ambient conditions are very wet, we advise to use a venting through the cable. A special vented cable can be delivered on request. (The normal venting will be removed)
- The covers must be fully engaged, so that moisture cannot ingress into the electronic housing. The covers must only be capable of being released or removed with the aid of a tool.
- Warranty is 1 year from delivery date.
Klay Instruments does not accept liability for consequential damage of any kind due to use or misuse of the Series 3000. Warranty will be given, to be decided by the manufacturer. Transmitter must be shipped prepaid to the factory on manufacturers authorization.
- Klay Instruments reserves the right to change the specifications.

Manufactured by:

 **KLAY-INSTRUMENTS**
www.klay-instruments.com

Nijverheidsweg 5
P.O. Box 13
Tel: +31521-591550
Fax: +31521-592046

7991 CZ DWINGELOO
7990 AA DWINGELOO
The Netherlands
E-Mail: info@klay.nl